

# Report

Report no. 7/26

**A life-cycle assessment  
tool for heavy-duty  
vehicles**

ISBN 978-2-87567-215-5



9 782875 672155 >

# A life-cycle assessment tool for heavy duty vehicles

This report was prepared by Pascal Smague, Olivier Guyon, Mickaël Loszka, Joris Melgar, (IFP Energies Nouvelles) and Roland Dauphin (Concawe)

Under the supervision of: Roland Dauphin and Dieter Walter (Concawe Science Executive)

This report was updated in 2026 with updated sections prepared by Joris Melgar, (IFP Energies Nouvelles) and Adrian Velaers (Concawe)

Contact: [fuels@concawe.eu](mailto:fuels@concawe.eu)

At the request of:

Concawe Special Task Forces on Life-Cycle Assessment (FE/STF-14) and Diesel fuel (FE/STF-25)

We thank for their contribution:

- IFP Energies nouvelles team members
- Members of FE/STF-14 and of FE/STF-25
- Members of FEMG and of RETMG
- Members of the secretariat

Reproduction permitted with due acknowledgement

## EXECUTIVE SUMMARY

This report is the supporting document to the life-cycle assessment tool for heavy-duty vehicles (HDVs) developed by IFP Energies nouvelles and commissioned by Concawe that was published in July 2023. It describes the simulation background behind the tool.

Transport related GHG emissions represent approximately a quarter of the European Union (EU) greenhouse gases (GHG) emissions, of which, commercial road transport represents approximately a third. Therefore reducing GHG emissions from heavy duty road vehicles is an important part of the EU's target to become carbon neutral by 2050.

Several technologies can contribute to heavy duty transport decarbonisation: Battery Electric Vehicles (BEVs, or their derivative, Catenary Electric Vehicles (CEVs)), Internal Combustion Engines Vehicles (ICEVs) running on low-carbon fuels (renewable diesel, renewable gas, low-carbon hydrogen), Hybrid Electric Vehicles (HEVs), Plug-in Hybrid Electric Vehicles (PHEVs) and Fuel Cell Electric Vehicles (FCEVs). Understanding the benefits and drawbacks of each solution from a life-cycle perspective for a given use case is difficult. The LCA tool described in this report aims at improving this understanding and assist in decision making.

HDVs have numerous vehicles categories, use cases and have access to many powertrains and energy carriers combinations. The tool allows to combine the following parameters to define specific use cases:

- 7 Powertrains and their efficiencies: ICEV (fuelled by diesel or diesel-like fuels, gas (compressed (CNG) or liquefied (LNG)) or hydrogen), HEV, PHEV, FCEV and BEV (and CEV);
- 5 Vehicle categories: Long-haul truck (Class5), delivery truck (Class2), city bus, coach, and refuse truck (for garbage collection);
- 5 categories of energy carriers: Diesel (fossil-based and derivatives such as B7, B30, B7+25%HVO), Diesel-like fuels with renewable characteristics (including HVO, B100 (100% FAME), e-Diesel, biomass-to-liquid, etc.), hydrogen (grey, blue or green), CNG and LNG (fossil-based, bio-based, e-fuel based), and Electricity (with variation on carbon intensity);
- Sensitivities around battery, fuel cell capacity and hydrogen tank production emissions;
- Number of battery packs used in the lifetime of the vehicle;
- Use cases (payload, trip profile, charging frequency)

Vehicle simulations were developed using Simcenter Amesim™ sketches. First, the simulations were calibrated using the “VECTO” tool (simulator for HDVs developed by the European Commission) on the “mainstream” ICEV configurations: this showed a good fit, with a less than 2% difference on fuel consumption on typical driving cycles. Then, the simulations were expanded to alternative powertrains (HEV, PHEV, FCEV, BEV). The vehicles configurations (powertrain characteristics, weight, efficiencies, battery capacity, etc.) and their conditions of use (driving cycles, payload) were selected based on a literature review of existing vehicles. The simulations results (energy consumptions) were cross-checked with data found in the literature and showed a fairly good consistency considering that the driving cycles used in the literature may vary and are not always described. Eventually, the vehicles simulations provide an energy consumption (expressed in L/100km, kg/100km or kWh/100km) for each vehicle configuration featuring the combined parameters mentioned above.

This energy consumption is converted in CO<sub>2</sub>eq emissions using the emission factors (tank-to-wheel, well-to-tank and recycled CO<sub>2</sub> contributions) of the different energy carriers (liquids, gases and electricity). On top of that are added the exhaust non-CO<sub>2</sub> emissions (CH<sub>4</sub> and N<sub>2</sub>O contributions, that are powerful GHGs, even when emitted in small quantities) and the emissions of manufacturing the vehicle (powertrain, chassis, battery, tank, tires), giving the life-cycle emissions of the vehicles expressed in gCO<sub>2</sub>eq/t.km (where “t” are the tons of goods transported).

An extensive use of this LCA tool for HDVs shows that the optimal options for decarbonization are highly dependent on the use case considered.

**Update 2026:**

The updates aim to improve methodological consistency between the passenger car and HDV tools, enhance the accuracy of emission estimates, and integrate more recent reference data.

Key modifications include the alignment of battery production emission factors, the update of electricity carbon intensity values based on 2024 data from ElectricityMaps, and the adoption of the PREMISE framework for modelling vehicle production emissions under European manufacturing conditions.

A mathematical model was developed from a Design of Experiments (DoE) simulation campaign, allowing the estimation of Tank-to-Wheel fuel consumption across various usage scenarios and climates. The updated datasets are fully integrated into the Power BI dashboards, ensuring that results remain transparent, traceable, and reflective of current technological and environmental conditions.

There were also improvements to the visualisation and functionality, a screenshot of the updated tool is below:

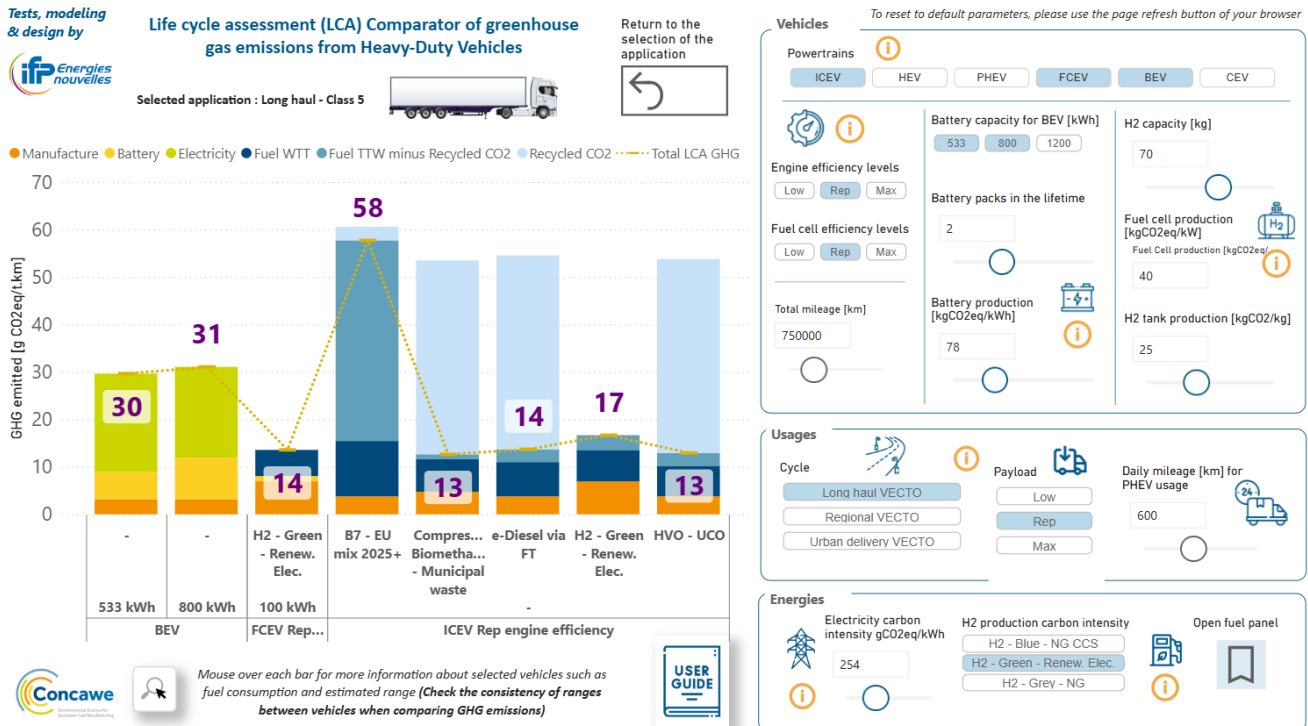



## KEYWORDS

Heavy Duty vehicles, CO<sub>2</sub> emissions, Life Cycle Assessment, Simulation, Interactive comparator tool, Renewable fuels, Hydrogen, Battery electric

## INTERNET

This report is available as an Adobe pdf file on the Concawe website. ([www.concawe.eu](http://www.concawe.eu))

### NOTE

*Considerable efforts have been made to assure the accuracy and reliability of the information contained in this publication. However, neither Concawe nor any company participating in Concawe can accept liability for any loss, damage or injury whatsoever resulting from the use of this information.*

*This report does not necessarily represent the views of any company participating in Concawe.*

<b>CONTENTS</b>		<b>Page</b>
<b>1.</b>	<b>INTRODUCTION</b>	<b>4</b>
1.1.	CONTEXT	4
1.2.	OBJECTIVES	4
1.3.	PROJECT PROGRAM AND REPORT STRUCTURE	5
<b>2.</b>	<b>VEHICLE SIMULATIONS</b>	<b>6</b>
2.1.	INTRODUCTION	6
2.2.	VEHICLE SIMULATION TOOL	8
2.2.1.	Presentation	8
2.2.2.	Validation of simulation tool	9
2.2.2.1.	Vehicle and powertrain definition	9
2.2.2.2.	Driving cycle	10
2.2.2.3.	Result	12
2.2.2.4.	Literature review on Diesel HD vehicle consumption	15
2.2.2.5.	Conclusion	16
2.3.	VEHICLES / POWERTRAIN DEFINITION AND SIMULATIONS	
	HYPOTHESIS	17
2.3.1.	Simulation matrix	17
2.3.2.	Sensitivity analysis	19
2.3.3.	Powertrain mass impact	19
2.3.4.	Simulation hypothesis	22
2.3.4.1.	Fuel properties	22
2.3.4.2.	Propulsion system	22
2.3.4.3.	Temperature condition	30
2.3.4.4.	Brake recovery and electric losses	30
2.3.4.5.	Brake recovery and electric losses	30
2.4.	SIMULATION RESULTS	32
2.4.1.	General status	32
2.4.2.	Main results and comparison with literature	32
2.4.2.1.	Long haul truck	32
2.4.2.2.	Delivery truck	33
2.4.2.3.	City bus	34
2.4.2.4.	Interurban bus / coach	35
2.4.2.5.	Refuse truck	36
<b>3.</b>	<b>LIFE-CYCLE ASSESSMENT</b>	<b>38</b>
3.1.	INTRODUCTION	38
3.2.	FUEL EMISSION FACTORS	38
3.2.1.	Tank-to-Wheel emissions	38
3.2.2.	Well-to-Tank emissions	38
3.2.3.	Recycled carbon dioxide	39
3.2.4.	Fuel blends	39
3.2.5.	Study limitation related to fuels	39
3.3.	CARBON INTENSITY OF THE ELECTRICITY MIX	39
3.4.	EMISSION FACTORS DUE TO VEHICLE PRODUCTION	40
3.4.1.	Chassis	41
3.4.2.	Tyres	41
3.4.3.	Powertrain	42
3.4.4.	Tank	42
3.4.5.	Battery	43

<b>4.</b>	<b>CONCLUSIONS</b>	<b>45</b>
<b>5.</b>	<b>GLOSSARY</b>	<b>47</b>
<b>6.</b>	<b>REFERENCES</b>	<b>49</b>
<b>7.</b>	<b>APPENDIX</b>	<b>51</b>
	7.1.1. Appendix 1: Vehicle / powertrain review from literature	51
	7.1.1.1. Long haul truck	51
	<i>Vehicle specifications</i>	51
	7.1.1.2. Delivery truck	57
	<i>Vehicle specifications</i>	57
	<i>Powertrains specifications</i>	59
	7.1.1.3. City bus	67
	<i>Vehicle specifications</i>	67
	<i>Powertrain specifications</i>	68
	7.1.1.4. Interurban bus	73
	<i>Vehicle specifications</i>	73
	<i>Powertrain specifications</i>	74
	7.1.1.5. Refuse truck	77
	<i>Vehicle specifications</i>	77
	<i>Powertrains specifications</i>	78
	7.1.2. Appendix 2: Vehicle / powertrain review from literature	81
	7.1.2.1. Long haul truck	81
	<i>Vehicle</i>	81
	<i>Powertrains</i>	82
	<i>Gearbox</i>	83
	7.1.2.2. Delivery truck	84
	<i>Vehicle</i>	84
	<i>Powertrains</i>	85
	7.1.2.3. City bus	87
	7.1.2.4. Interurban bus	88
	7.1.2.5. Refuse truck	90

## 1. INTRODUCTION

### 1.1. CONTEXT

Transport related GHG emissions represent approximately a quarter of the European Union (EU) greenhouse gases (GHG) emissions, out of which commercial road transport represents approximately a third of this. In the context of aiming at reaching carbon neutrality in 2050, reducing heavy duty transport related GHG emissions represents an important stake. When considering each vehicle individually, there are several ways to consider their GHG emissions:

- The Tank-to-Wheel (TtW) approach only accounts for the tailpipe emissions;
- The Well-to-Wheel (WtW) approach is more complete and takes into account the GHG emissions related to the production of the energy carriers
- The Life Cycle Assessment (LCA) approach is holistic and also takes into account the GHG emissions related to the production of capital goods that are necessary to the transport system.

Obviously, the LCA approach is the most relevant to climate-related issues. Nevertheless, it is also challenging and dependent on the scenarios and use cases studied (i.e. combined assumptions). In this context, the passenger cars life-cycle assessment tool<sup>1</sup> developed by IFP Energies nouvelles and commissioned by Concawe in 2022 showed to be an interesting asset as it allows to combine in a simple way a complex set of options and use cases following the user's own approach.

After accessing this LCA tool, one of the requests often received from the users was to develop a similar tool for evaluating the life-cycle emissions of heavy-duty vehicles. This request takes place in the context of the revision of the CO<sub>2</sub> standards for heavy duty vehicles by the European Commission.

Several technologies can contribute to heavy duty transport decarbonisation: Battery Electric Vehicles (BEVs, or their derivative, Catenary Electric Vehicles (CEVs)), Internal Combustion Engines (ICE) running on low-carbon fuels (renewable diesel, renewable gas, low-carbon hydrogen), hybridized (Hybrid Electric Vehicles (HEVs), Plug-in Hybrid Electric Vehicles (PHEVs)) or not, and Fuel Cell Electric Vehicles (FCEVs). Understanding the benefits and drawbacks of each solution from a life-cycle perspective for a given use case is difficult. The tool described here is intended to enhance comprehension and facilitate decision-making.

### 1.2. OBJECTIVES

The objective of this study is to develop a life-cycle assessment online interactive tool for heavy duty vehicles in real-world conditions, similar to the one previously developed for passenger cars. This includes:

---

<sup>1</sup> [www.carsCO2comparator.eu](http://www.carsCO2comparator.eu)

- LCA CO<sub>2</sub>eq emissions (g/km) segregated by stage of life (vehicle manufacture, electricity, fuel production WtT, TtW emissions and absorbed CO<sub>2</sub> during the production of the fuel) ;
- Overall energy Consumption: Fuel Consumption TtW (L/100km or kg/100km) and Electrical Consumption (kWh/100km)
- And spans the following conditions:
  - Powertrains used and their efficiencies
  - Vehicle categories
  - Sensitivities around battery, fuel cell and hydrogen tank capacity and emissions during their production
  - Number of battery packs used in the lifetime of the vehicle
  - Use cases (payload, trip profile, charging frequency)
  - Fuels used
  - Carbon intensity of the electricity mix

It is also the objective for the study to remain relevant over time and to evolve as assumptions change or better data become available. The 2026 update identified the areas where significant new information was available and the updates, now detailed in this revised report, were made.

### 1.3. PROJECT PROGRAM AND REPORT STRUCTURE

The project program is composed of two parts:

- Part 1: Vehicle simulations, which is the main subject of this report, described in paragraph 2.
- Part 2: Life-cycle assessments, which cover the emissions related to the manufacture and recycling of the vehicles and the energy carriers, described in paragraph 4.

## 2. VEHICLE SIMULATIONS

### 2.1. INTRODUCTION

In the vehicles simulation phase of the study, typical figures for energy consumption of current and future propulsion systems for heavy duty vehicles (HDV) were assessed. This part of the study is related to the Tank-to-Wheel (TTW) analysis providing vehicle energy consumption, technical definition of selected HDV and associated powertrain as input for the LCA. This study focuses on energy consumptions and GHG emissions and therefore pollutant emissions were not included in the vehicle simulations. However, greenhouse gases contributions from CH<sub>4</sub> and N<sub>2</sub>O emissions were factored in. These additional GHG emission contributions were added up and put on top of the other emissions based on data collected in the literature (see paragraph 4 for more details).

Vehicle simulations aim to estimate overall energy consumption (kWh/100km) of HDV vehicles as well a fuel consumption (L/100km for liquid fuels and kg/100km for gaseous fuels) and electrical consumption (kWh/100km) depending on considered powertrains.

Five typical categories of HDVs, representative of the European HDV market, were identified in the scope of the study by Concawe members:

- A Heavy-Duty Vehicle (HDV) also referred as long-haul vehicle with a maximum weight of around 44 tons;
- A Medium Duty Vehicle (MDV) also referred as delivery truck with a maximum weight of around 19 tons;
- A 12m non articulated city bus;
- An interregional coach (bus);
- A 26t utility truck also referred as refuse truck.

For each of these vehicles, five categories of powertrains were evaluated:

- Conventional powertrain with Internal Combustion Engine for ICEV (Internal Combustion Engine Vehicle)
- Hybrid Electric powertrain for HEV (Hybrid Electric Vehicle)
- Plug-in Hybrid Electric powertrain for PHEV (Plug-in Hybrid Electric Vehicle)
- Hydrogen fuel Cell powertrain for FCEV (Fuel Cell Electric Vehicle)
- Battery Electric powertrain for BEV (Battery Electric Vehicle)
- Catenary Electric Vehicle CEV (see paragraph 4 for more details)

Furthermore, four categories of energy carriers were considered:

- Diesel type fuels (for ICEVs, HEVs and PHEVs): fossil-based and derivatives such as B7, B30 or B7+25%HVO, and diesel-like fuels with renewable characteristics such as HVO, B100 (100% FAME), e-Diesel, BtL, etc.
- Hydrogen (for ICEVs and FCEVs): grey, blue or green;
- Gas (for ICEVs): compressed natural gas (CNG) and liquefied natural gas (LNG), fossil-based, bio-based or e-fuel-based
- Electricity (for PHEVs and BEVs), with variation on carbon intensity

Energy consumption figures of vehicles were evaluated considering vehicle representative cycles depending on vehicle category:

- For HDV long haul truck:
  - “high speed” cycles corresponding to national and international travels
  - Local / urban trip for last mile delivery
- For MDV delivery truck:
  - “high speed” cycles corresponding to national and international travels
  - delivery / urban trip for last mile delivery
- For city bus:
  - urban transport including medium and low speed travels
- For interregional bus:
  - “high speed” cycles corresponding to national and international travels
- For refuse truck:
  - Local / urban low and medium speed trip including garbage collection phases.

A nominal simulation matrix including vehicle categories, powertrain architectures, and selected energy carrier was considered as nominal simulation set. In addition, to this nominal set of simulations a sensitivity analysis was considered around nominal configurations (default vehicle and powertrain sizing). For the sensitivity analysis, the following parameters were investigated:

- Vehicle payload
- Vehicle driving cycle
- ICE peak efficiency (for ICEVs, HEVs and PHEVs)
- Battery capacity (for BEVs)
- Fuel cell efficiency (for FCEVs)
- Charging frequency (for PHEVs)

Note: all the simulations were operated at nominal temperature (20°C) with an ambient start, and there is no thermal variation since it requires substantial amount of experimental data for each category of vehicles.

## 2.2. VEHICLE SIMULATION TOOL

### 2.2.1. Presentation

For vehicle simulation the IFPEN simulation platform: “Drivesym” (built on Simcenter Amesim) has been chosen. This expert tool is designed for calculating energy consumption and CO<sub>2</sub> emissions across various powertrain types as well as energy carriers. It supports the modelling of light duty vehicles (LDVs) and heavy-duty vehicles (HDVs), enabling virtual drive simulations on different routes for complex powertrain configurations. These configurations include conventional ICE as well as hybrid, fuel cell and electric battery powertrains, all modelled in a forward approach. The tool offers the convenience of automated bench simulations by utilizing a Python interface that interacts with the Simcenter Amesim sketches. Below is an overview of the simulation workflow.

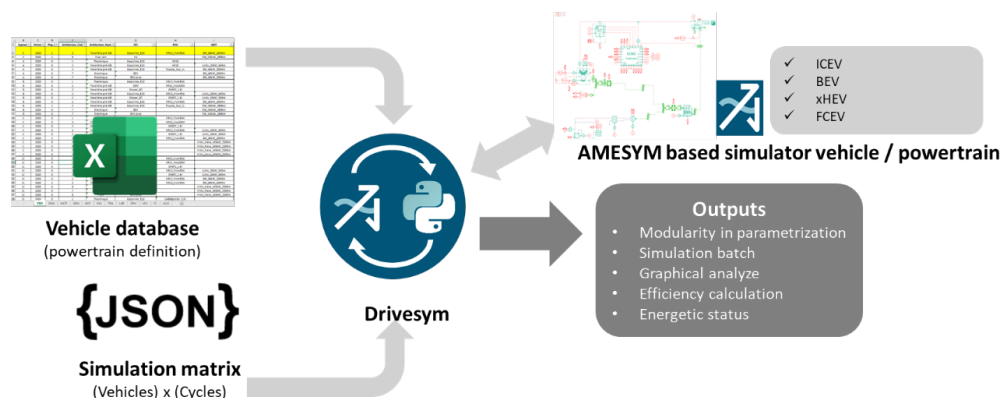

**Figure 1** Vehicle simulation workflow

## 2.2.2. Validation of simulation tool

To gain confidence in the results produced by the IPEN simulation tool, an initial comparison was conducted with the European VECTO simulation tool.

This comparison was performed on all five vehicle types of the ICE Diesel powertrain configurations since VECTO-3.3.13.2924 can only simulate vehicle energy consumption for conventional powertrains.

For the comparison, vehicle / powertrain specifications and driving cycles were collected in VECTO database and VECTO simulations were performed in the “Engineering Mode” allowing to set more advanced parameters in VECTO.

### 2.2.2.1. Vehicle and powertrain definition

For fair comparison, vehicle and powertrain definitions were replicated in both simulation tools. Below, you will find the comprehensive specifications for the five vehicle/powertrain configurations. During the cross-comparisons, simulations of ADAS solutions (S&S, Eco-roll, Predictive Cruise control ...) were disabled. The impact of these ADAS systems on fuel consumption was assessed using the VECTO tool for the class 5 vehicle, as explained in the subsequent section of this report.

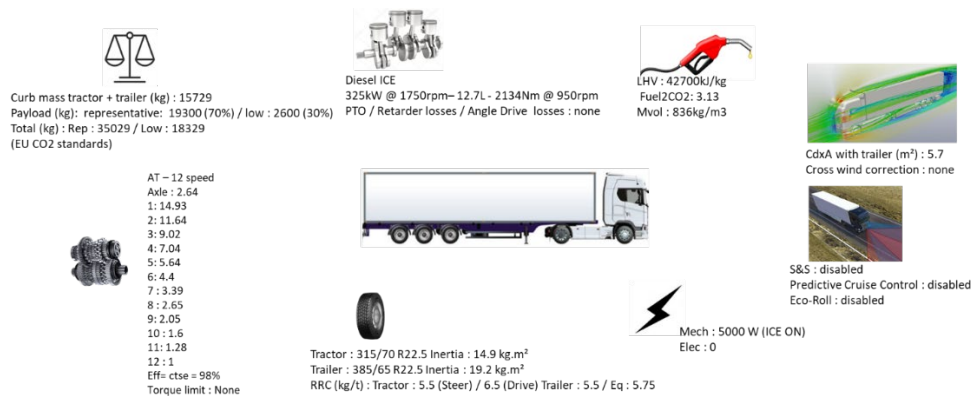

Figure 2 Class 5 vehicle specifications for Drivesym / VECTO comparison

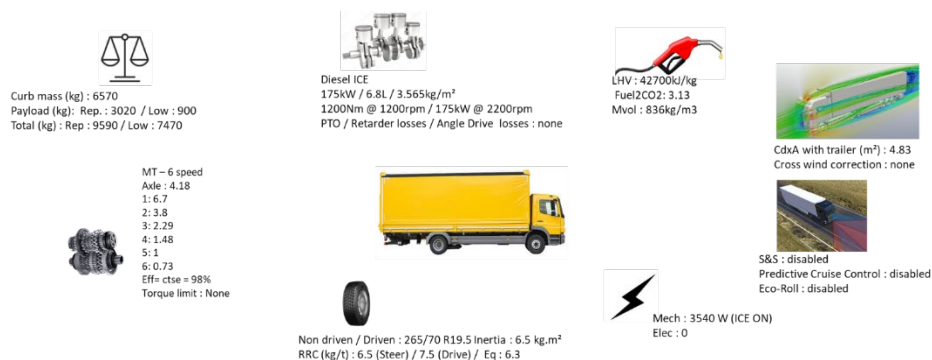
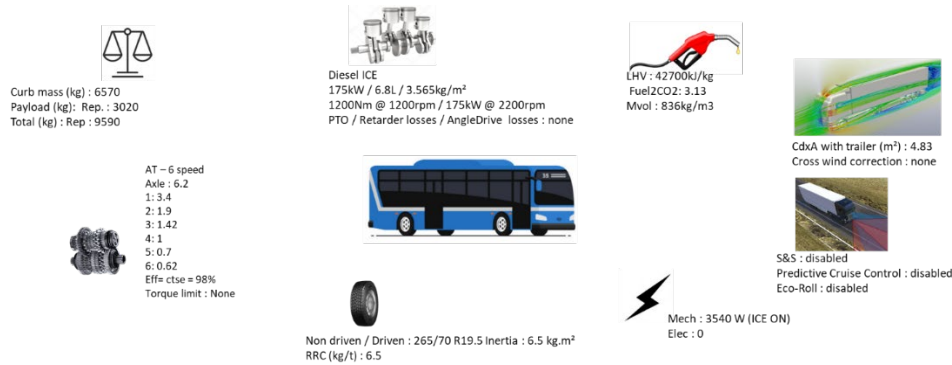

Figure 3 Class 2 vehicle specifications for Drivesym / VECTO comparison

### City bus vehicle with ICE Diesel powertrain



**Figure 4** City bus vehicle specifications for Drivesym / VECTO comparison

### Interurban coach (bus) vehicle with ICE Diesel powertrain

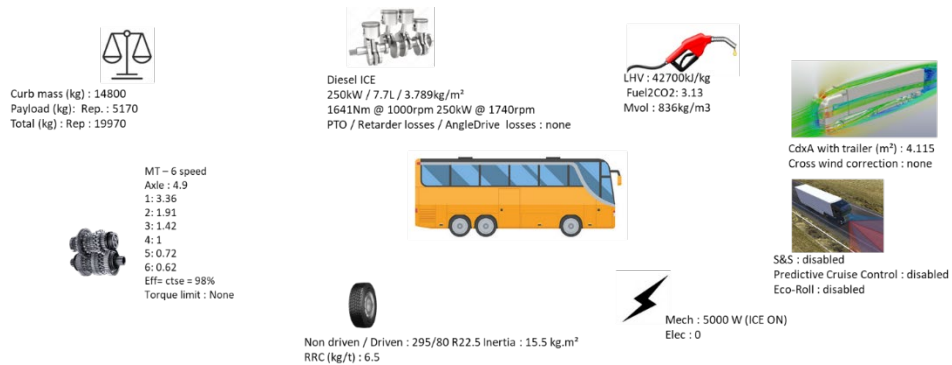

**Figure 5** Interurban bus vehicle specifications for Drivesym / VECTO comparison

### Refuse truck with ICE Diesel powertrain

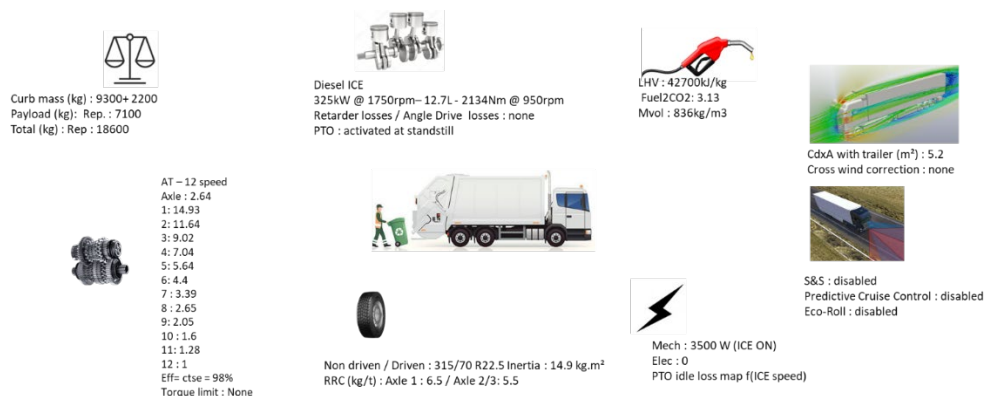

**Figure 6** Refuse truck vehicle specifications for Drivesym / VECTO comparison

#### 2.2.2.2. Driving cycle

Five driving cycles from the VECTO database were utilized to facilitate the comparison between VECTO and Drivesym. Additionally, a dedicated cycle encompassing driving displacements and Power Take Off (PTO) operations, referred to as the "Municipal Utility PTO," was employed specifically for the refuse truck configuration. This cycle emulates urban driving conditions, featuring multiple standstill phases intertwined with a PTO cycle

that accurately reflects refuse collection activities. The table below provides an overview of the VECTO cycles, categorized by vehicle types.

Vehicle type	Representative cycle
class 5 - 4x2 HDV trailer	Long-haul Regional Delivery Urban Delivery
class 2 - 4x2 MDV rigid truck	Coach InterUrban
Regional Delivery	Urban
Urban Delivery	Municipal Utility with PTO

**Table 1** List of simulated vehicle and associated cycle for VECTO / Drivesym comparison

Below are presented, for information, the main characteristics of these driving cycles: the speed and slope are indicated in blue /orange and the PTO duty cycle for refuse truck in blue.

Long haul / Delivery truck cycles

**Long Haul**

Distance : 100.2km  
Av. speed : 82.4km/h

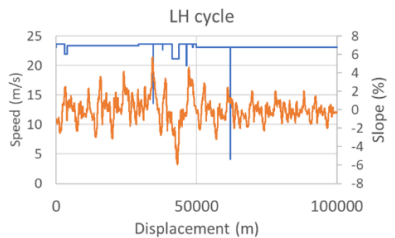

**Regional delivery**

Distance : 100km  
Av. speed : 67.8km/h

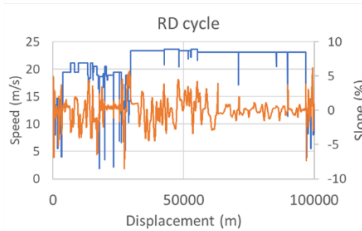

**Urban delivery**

Distance : 100km  
Av. speed : 38.8km/h

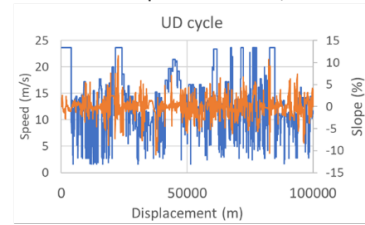

City bus cycle

**Urban**

Distance : 39.5km  
Av. speed : 27.4km/h

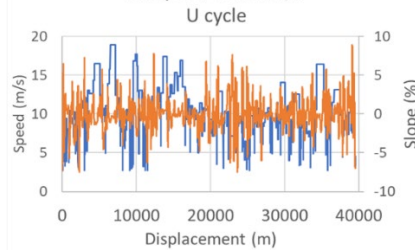

Interurban bus cycle

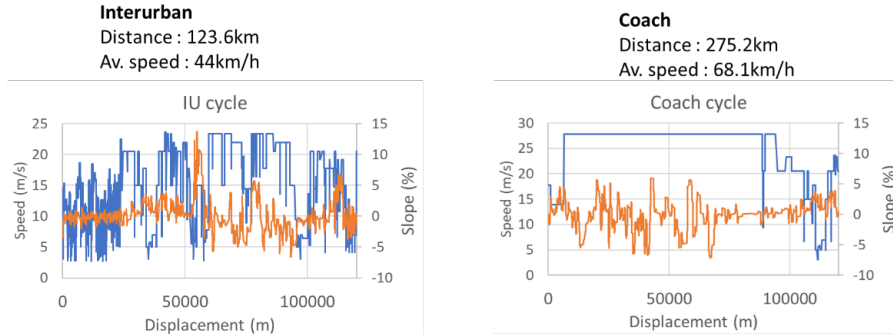

Refuse truck cycle

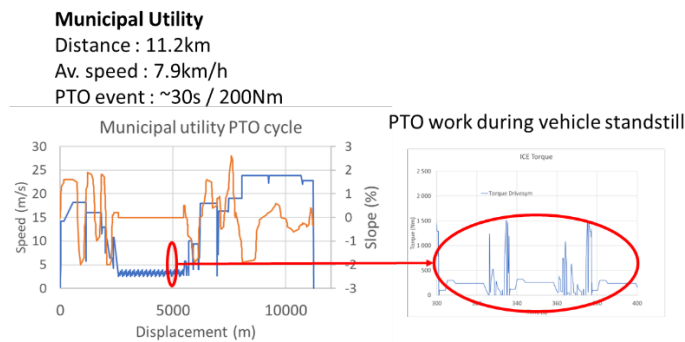

**Figure 7** VECTO cycle specifications for comparison between Drivesym and VECTO

**2.2.2.3. Result**

The cross-simulations reveal consistent fuel consumption results between both simulation tools, regardless of the duty cycle and vehicle load. This outcome did provide confidence in utilizing the Drivesym IFPEN simulator to assess advanced electrified powertrains for future HDV energy consumption evaluations. Below is a summary of the simulation comparison results for each vehicle class.

**Class 5 vehicle**

A maximum fuel difference of 1.7% is observed on the "Urban delivery" cycle, which can be attributed to variations in the driver model and gear shift strategy between the two simulators. On the other hand, a satisfactory fuel difference of less than 1% was noticed when considering the typical class 5 average weighted mission, comprising Long Haul Representative load ("LHR": 63%), Long Haul Low load ("LHL": 27%), Regional Delivery Representative load ("RDR": 7%) and Regional Delivery Low load ("RDL": 3).

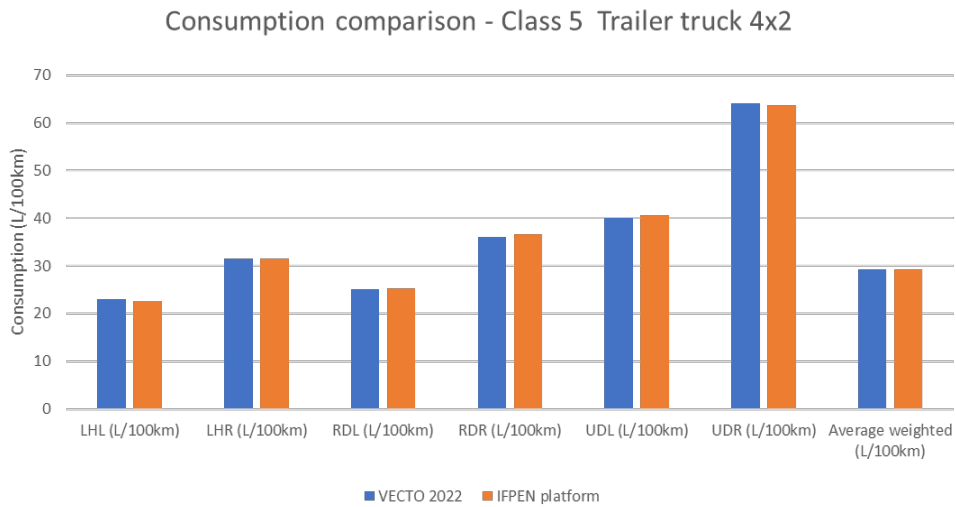

**Figure 8** Class 5 consumption comparison (VECTO vs. Drivesym)

### Class 2 vehicle

A maximum fuel consumption difference of 2.7% was observed on the "Urban delivery" cycle, with the same origins of differences as previously explained. On the other hand, a satisfactory fuel difference of approximately 2% was observed for the typical class 2 average weighted mission, consisting of Long Haul Representative load ("LHR": 14%), Long Haul Low load ("LHL": 6%), Regional Delivery Representative load ("RDR": 24%), Regional Delivery Low load ("RDL": 6%), Urban Delivery Representative load ("UDR": 35%), and Urban Delivery Low load ("UDL": 15%).

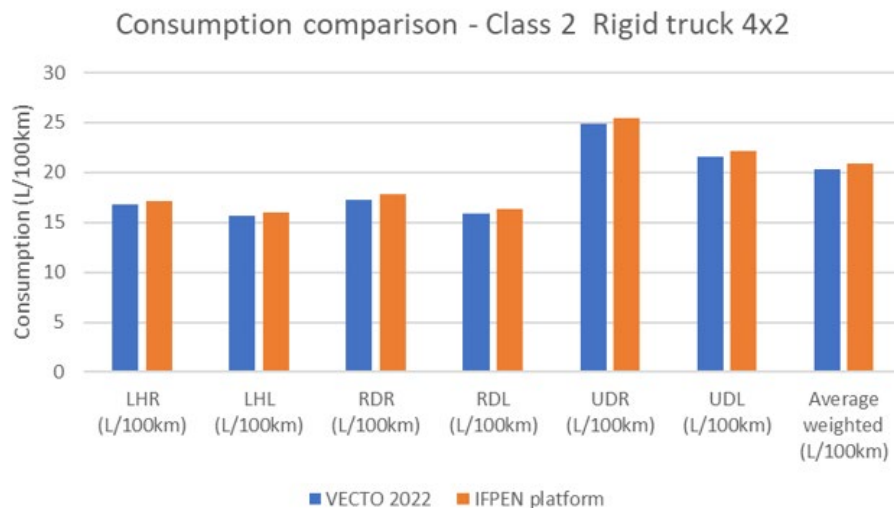

**Figure 9** Class 2 consumption comparison (VECTO vs. Drivesym)

### City bus vehicle

A fuel consumption overestimation of 2% was observed in the Drivesym platform compared to the estimation provided by VECTO.

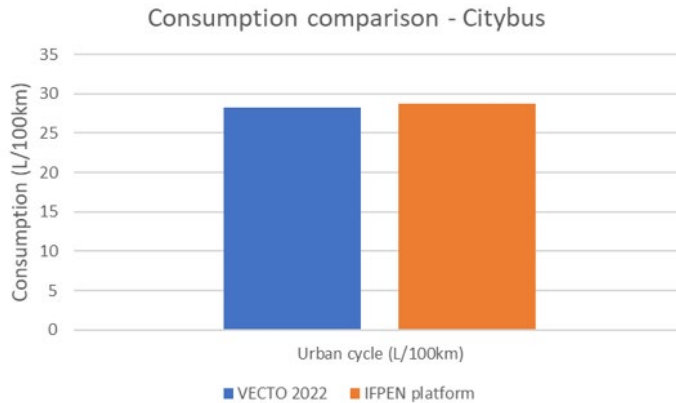

**Figure 10** City bus consumption comparison (VECTO vs. Drivesym)

### Interurban bus vehicle

An overestimation of maximum 1.7% in fuel consumption was observed in the Drivesym platform for the "Interurban" cycle when compared to VECTO.

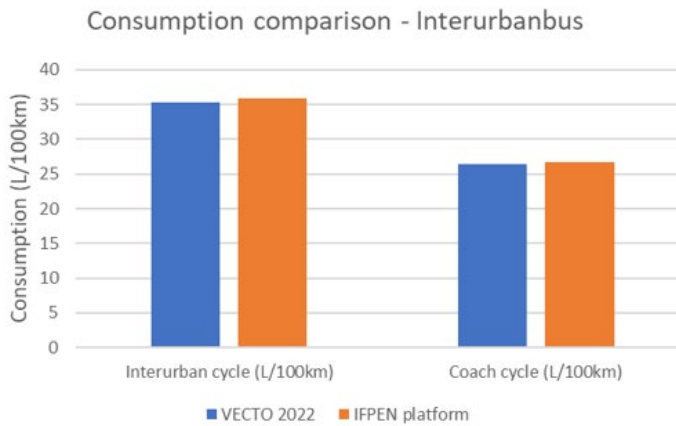

**Figure 11** Interurban consumption comparison (VECTO vs. Drivesym)

### Refuse truck vehicle

The Drivesym simulator, originally designed for vehicles with conventional internal combustion engines (ICE), was adjusted to incorporate Power Take Off (PTO) work within the driving cycle. This adaptation was appropriate and resulted in a fuel estimation difference of less than 2% between the two simulators.

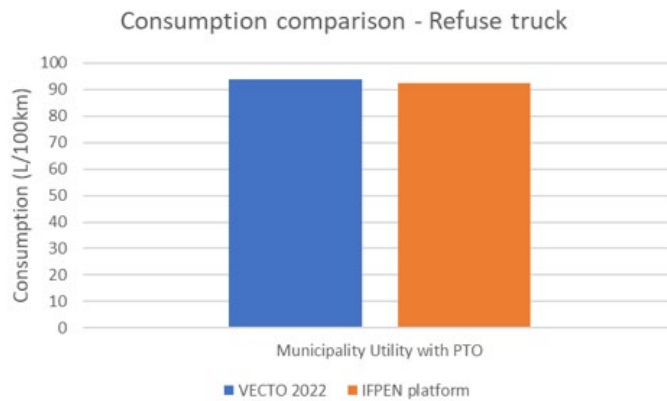

Figure 12 Refuse truck consumption comparison (VECTO vs. Drivesym)

2.2.2.4. Literature review on Diesel HD vehicle consumption

A literature review was performed following the simulations to reinforce confidence in the simulation results but also to evaluate VECTO cycles severity for each vehicle. The review on vehicle consumption is detailed in the table below. It highlights that generally, VECTO cycles are relevant to estimate vehicle consumption with a good confidence with observed consumptions, except for city bus and for refuse truck.

For city buses, the Urban VECTO cycle appears to reflect a widespread urban usage pattern, displaying a consumption profile that is lower than what is typically observed in highly congested city centers. Consequently, an additional cycle with a lower average speed was introduced: the TFL UIP cycle (Transport for London Urban Inter Peak), which was generously provided by Transport for London (tfl.gov.uk). This new cycle was designed to represent the intense urban usage characteristic of densely populated city centers. The driving cycle's speed profile is illustrated in the figure below.

Furthermore, it was noted that the vehicle curb mass suggested by VECTO was inadequate for a 12-meter-long city bus. Thus, this mass was adjusted based on relevant literature during the second phase of simulations, which focused on evaluating powertrains.

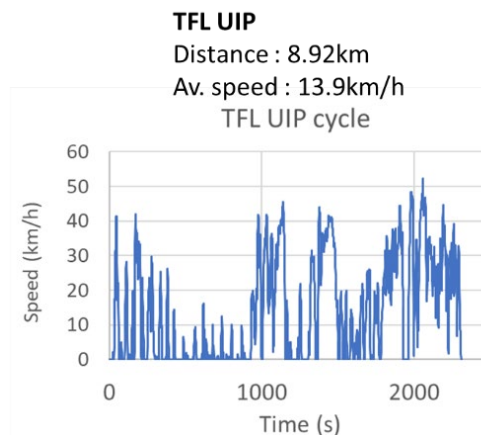

Figure 13 TFL UIP cycle for city bus (courtesy of Transport for London)

For refuse trucks, the simulations have revealed fuel consumption levels higher than those indicated in the literature. To address this, a modified approach was suggested for the second phase of simulations: instead of using a fixed payload throughout the driving cycle, an evolving payload was proposed. This adjustment aims to better emulate the dynamics of garbage collection during the drive.

The table below provides a comprehensive breakdown of the consumption comparison between the simulation results and the findings from the literature review for all the vehicles.

Vehicle type	Consumption in literature	Literature reference	IFPEN simulations in Drivesym /VECTO
Class 5 long haul	30L/100km for 5-LH usage 33L/100km for 5-RD usage -60-66L/100km for 5-UD usage  31.4L/100km (Long haul truck average)	ICCT 2021 Tranplhyn 2022 / E4T CNR 2020	31.5L/100km for 5-LH VECTO 36.1L/100km for 5-RD VECTO 64L/100km for 5-UD VECTO
Class 2 Delivery truck	27L/100km for class 2 average	ICCT 2023	17.3L/100km for 2-RD VECTO 25L/100km for 2-UD VECTO
City bus	53.8L/100km (12m Bus very dense usage) 32.1L/100km (12m urban Bus diffuse usage) 34.9L/100km (12m Bus average)	MTE 2018 CATP 2022	28.7L/100km (12m-9.6t) Urban VECTO 36L/100km (12m-9.6t) TFL-UIP
Inter-urban / coach	34.6L/100km (12m- 16t) Interurban VECTO 26.9L/100km (Bus and coach Interurban cycle) 34.9L/100km (12m Coach average)	Tranplhyn 2022 MTE 2018	35.3L/100km (12m - 19t) Inter-urban VECTO
Refuse truck	68L/100km (average collect usage)	ADEME	94L/100km (Municipal Utility cycle with PTO full payload) 80L/100km (Municipal Utility cycle with PTO evolutive payload)

**Table 2** Comparison of Fuel Consumption between Literature and Simulation for Diesel Heavy Duty Vehicles (HDVs)

#### 2.2.2.5. Conclusion

The initial simulation phase affirms the capability of the Drivesym tool to accurately replicate the fuel consumption of Heavy Duty Vehicles (HDVs) equipped with conventional internal combustion engine (ICE) powertrains. Furthermore, this phase validates the overall suitability of the selected simulation cycles in accurately emulating different vehicle categories.

## 2.3. VEHICLES / POWERTRAIN DEFINITION AND SIMULATIONS HYPOTHESIS

The second phase of the simulation work is focused on establishing suitable vehicle/powertrain configurations to serve as generic representatives for each category of Heavy Duty Vehicles (HDVs). In the preceding phase, certain generic vehicle definitions within the VECTO database were found inadequate for the intended categories—such as the case of city buses, where the vehicle curb mass was insufficient for a 12-meter city bus. Furthermore, the precise specifications of powertrains need to be delineated for vehicle simulations and comprehensive tank-to-wheel assessments. This includes in-depth investigations into a variety of powertrain types and energy carriers.

For each vehicle category, a thorough examination was proposed, encompassing an extensive literature review involving scientific papers and manufacturer communications. Additionally, a commercial review was conducted to discern the most appropriate vehicle specifications and powertrain designs, taking into account the latest advancements in the field. The outcome of this meticulous vehicle/powertrain review was shared with Concawe and can be found in Appendix 1 of the report.

### 2.3.1. Simulation matrix

According to vehicle / powertrain specifications coming from literature / commercial review a generic matrix was defined in accordance with Concawe for each vehicle / powertrain configuration. This matrix establishes the standard configuration of each vehicle to be simulated. Comprehensive information regarding the characteristics of each vehicle and its corresponding powertrain can be found in Appendix 2 of the report.

The table below outlines the primary powertrain characteristics that define the various powertrain types.

Powertrain type	Energy carrier	Vehicle
ICE	Diesel-like / Gas-like / H2	ICE displacement (L) / ICE max power (kW) / ICE peak efficiency (%) / ICE max torque (Nm) / Gear number on gearbox (gears)
HEV / PHEV	Diesel-like / Electricity	ICE displacement (L) / ICE max power (kW) / ICE peak efficiency (%) / ICE max torque (Nm) / Gear number on gearbox (gears) / Battery energy (kWh) / Electric machine max power (kW) / torque (Nm) / Gear number on gearbox (gears)
BEV	Electricity	Battery energy (kWh) / Electric machine max power (kW) / Torque (Nm) / Speed (rpm) / Gear number on gearbox (gears)
FCEV	H2	Fuel cell max power (kW) / Fuel cell peak efficiency (%) / Hydrogen quantity (kg) / Battery energy (kWh) / Electric machine max power (kW) / torque (kW) / Speed (rpm) / Gear number on gearbox (gears)

**Table 3** Powertrain characteristics for HDV definition

In the second table, the chosen specifications for these characteristics, which have been adopted for the simulations of the respective vehicles, are delineated.

Powertrain	Energy carrier	Long haul truck Class 5	Delivery truck Class 2	City bus 12m	Coach / Interurban bus	Refuse truck
ICE	Diesel	12.8L / 400kW / 46% / 2700Nm / 12gears	7.1L / 225kW / 42.4% / 1130Nm / 12gears	7.1L / 225kW / 42.4% / 1130Nm / 6 gears	7.7L* / 250kW / 46% / 1400Nm / 6 gears	7.7L* / 250kW / 46% / 1400Nm / 6 gears
	CNG/LNG	12.9L / 340kW / 36.5% / 2000Nm / 12gears	7.1L / 225kW / 36% / 1150Nm / 12gears	7.1L / 225kW / 36% / 1150Nm / 6 gears	7.1L / 225kW / 36% / 1150Nm / 6 gears	7.1L / 225kW / 36% / 1150Nm / 6 gears
	H2	15.2L / 410kW / 44.1% / 1950Nm / 12gears	9.3L / 220kW / 44.1% / 1100Nm / 12gears	9.3L / 220kW / 44.1% / 1100Nm / 6 gears	9.3L / 220kW / 44.1% / 1100Nm / 6 gears	9.3L / 220kW / 44.1% / 1100Nm / 6 gears
HEV	Diesel	12.8L / 400kW / 46% / 2700Nm / batt 20kWh/ e-motor 150kW / 12gears	7.1L / 225kW / 42.4% / 1130Nm / batt 30kWh/ e-motor 100kW-280Nm / 12gears	7.1L / 225kW / 42.4% / 1130Nm / batt 20kWh/ e-motor 35kW - 250Nm / 6 gears	7.7L* / 250kW / 46% / 1400Nm / batt 25kWh/ e-motor 120kW - 800Nm / 6 gears	7.7L* / 250kW / 46% / 1400Nm / batt 25kWh/ e-motor 120kW - 800Nm / 6 gears
PHEV	Diesel / Electricity	12.8L / 400kW / 46% / 2700Nm / batt 130kWh/ e-motor 250kW - 1100Nm / 12gears	7.1L / 225kW / 42.4% / 1130Nm / batt 100kWh/ e-motor 250kW - 1100Nm / 12gears	7.1L / 225kW / 42.4% / 1130Nm / batt 100kWh/ e-motor 160kW-400Nm / 6gears	7.7L* / 250kW / 46% / 1400Nm / batt 100kWh/ e-motor 250kW-1100Nm / 6gears	7.7L* / 250kW / 46% / 1400Nm / batt 100kWh/ e-motor 250kW - 1100Nm / 6gears
BEV	Electricity	batt 533kWh / e-motor 350kW-2000Nm-5krpm / 2gears	batt 400kWh / e-motor 250kW-1100Nm / 2gears	batt 533kWh / e-motor 250kW-1100Nm / 2gears	batt 667kWh / e-motor 300kW - 1500Nm / 2gears	batt 400kWh / e-motor 300kW-1500Nm / 2gears
FCEV	H2	FC 225kW 65% / H2 50kg / batt 100kWh / e-motor 350kW-2000Nm-5krpm / 2gears	#1: FC 225kW 65% / H2 30kg / batt 20kWh / e-motor 250kW-1100Nm / 2gears  #2*: FC 75kW 65% / H2 15kg / batt 100kWh / e-motor 250kW-1100Nm / 2gears	FC 75kW 65% / H2 35kg / batt 75kWh / e-motor 250kW-1100Nm / 2gears	FC 225kW 65% / H2 35kg / batt 75kWh / e-motor 300kW - 1500Nm / 2gears	FC 75kW 65% / H2 25kg / batt 75kWh / e-motor 300kW - 1500Nm / 2gears

Table 4 HDV powertrain definitions

\* #2 FC vehicle with fuel cell as range extender for class 2 delivery truck was finally not considered in simulations as FCEV nominal powertrain

### 2.3.2. Sensitivity analysis

In addition to the nominal matrix, variations in crucial powertrain characteristics (such as ICE and fuel cell efficiency, battery energy) and vehicle usages (including driving cycle, payload, auxiliary load, grid recharge frequency) were examined to assess the impact of these parameters on the fuel and energy consumption of the vehicles.

The image below highlights the sensitivity analysis conducted on vehicle simulations for each vehicle and powertrain category.

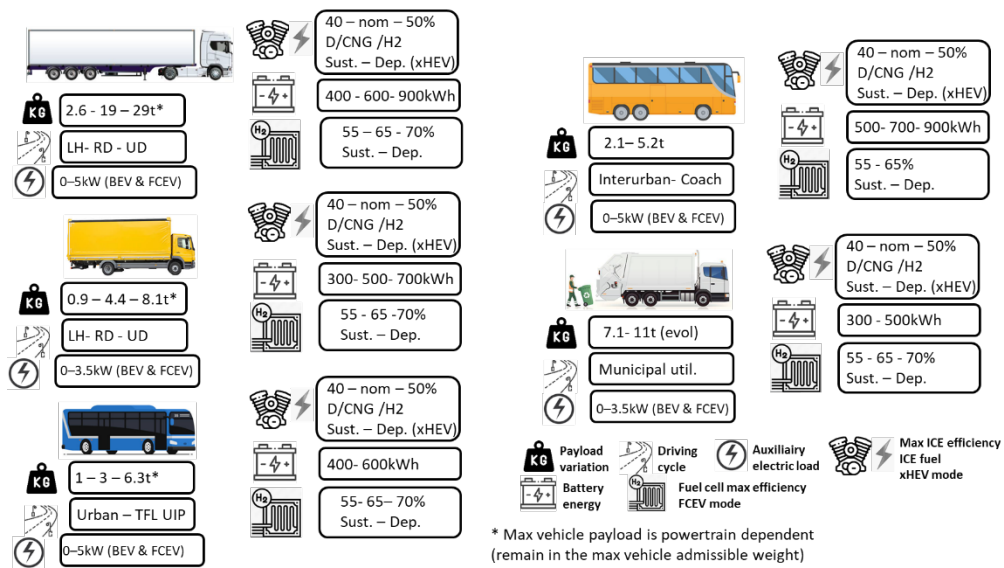

Figure 14 Sensitivity analysis around nominal vehicle / powertrain

### 2.3.3. Powertrain mass impact

To ensure an unbiased evaluation between electrified vehicles and conventional vehicles, the vehicle curb mass was adjusted, taking into account the powertrain type and the varying energy density of the components. The reference curb mass for each of the five vehicle categories was established for the ICE Diesel powertrain. Subsequently, these curb masses were recalibrated when considering other powertrain options.

The energy density of powertrain components, as detailed in the table below, was taken into account when assessing the mass of the powertrains.

The estimation of powertrain mass encompasses several elements, including sources such as the internal combustion engine (ICE), electric machine along with associated electronics, fuel cell, fuel storage tank, and electrochemical energy storage (battery).

Formulas for calculating the vehicle curb mass are provided to illustrate the procedure for BEV and FCEV vehicles:

$$\begin{aligned} \text{Powertrain mass}_{ICE\_Diesel} \\ = \text{Power}_{ICE\_Diesel} / \text{Density}_{ICE\_Diesel} + \text{Volume}_{Diesel} * \text{Density}_{Diesel} / \text{Density}_{Diesel\ storage} \end{aligned}$$

$$\begin{aligned} \text{Powertrain mass}_{BEV} \\ = \text{Power}_{emotor} / (\text{Density}_{emotor} + \text{Density}_{electronics}) + \text{Battery capacity}_{BEV} / \text{Density}_{batt} \end{aligned}$$

$$\begin{aligned} \text{Powertrain mass}_{FCEV} \\ = \text{Power}_{FC} / \text{Density}_{FC} + \text{Power}_{emotor} / (\text{Density}_{emotor} + \text{Density}_{electronics}) \\ + \text{Battery capacity}_{FCEV} / \text{Density}_{batt} + \text{Mass}_{H2} / \text{Density}_{H2\ storage} \end{aligned}$$

$$\text{Vehicle curb mass}_{BEV} = \text{Vehicle curb mass}_{ICE\_Diesel} - \text{Powertrain mass}_{ICE\_Diesel} + \text{Powertrain mass}_{BEV}$$

$$\text{Vehicle curb mass}_{FCEV} = \text{Vehicle curb mass}_{ICE\_Diesel} - \text{Powertrain mass}_{ICE\_Diesel} + \text{Powertrain mass}_{FCEV}$$

	Density selected for study
ICE (kW/kg)	0.3 (ICE Diesel / Gas) 0.25 <sup>2</sup> (ICE H2)
FCEV (kW/kg_sys)	0.6 <sup>3</sup>
H2 fuel storage (kgH2/kg)	0.06 <sup>4</sup>
Battery (Wh/kg)	200 <sup>5</sup>
e-motor (kW/kg)	1.5 (HEV/PHEV) 2.9 (BEV/FCEV)
Electronics (kW/kg)	15 (Inverter) 3 (Charger) 1.2 (DC/DC)

**Table 5** Powertrain components energy density

During the simulations for ICE, PHEV, and FCEV configurations, fuel quantity has been taken as a variable, accounting for energy carriers, vehicle categories, and their corresponding anticipated ranges. The following provides a comprehensive breakdown of the fuel quantities considered for all vehicle/powertrain configurations.

<sup>2</sup> <https://fptengine>

<sup>3</sup> DOE Hydrogen and Fuel Cells Program Record (2020)

<sup>4</sup> <https://hyfindr.com/product-category/components/hydrogen-tanks/> (type IV tank)

<sup>5</sup> JRC Circular Economy Perspectives for the Management of Batteries used in Electric Vehicles, Ricardo, 2019

	Density selected for study
Long haul	500L - B0 (ICE, HEV, PHEV) 120kg - CNG (ICE) 50kg - H2 (ICE, FCEV)
Delivery truck	300L - B0 (ICE, HEV, PHEV) 80kg - CNG (ICE) 30kg - H2 (ICE, FCEV)
City bus	300L - B0 (ICE, HEV, PHEV) 80kg - CNG (ICE) 35kg - H2 (ICE, FCEV)
Interurban bus	500L - B0 (ICE, HEV, PHEV) 80kg - CNG (ICE) 35kg - H2 (ICE, FCEV)
Refuse truck	300L - B0 (ICE, HEV, PHEV) 80kg - CNG (ICE) 25kg - H2(ICE, FCEV)

**Table 6** Fuel quantity hypothesis in vehicle

For all vehicles, both a low and representative payload were taken into account. These values were obtained from VECTO for freight transport or were derived from proposals by IFPEN/CONCAWE, which consider the average predictable number of occupants for passenger transportation vehicles. Additionally, a maximum payload was considered and adjusted, if needed, taking into consideration the impact of powertrain mass and the vehicle's maximum permissible weight. An example of this is illustrated for Battery Electric Vehicles (BEVs) using the following formula.

$$\begin{aligned}
 \text{Payload max}_{BEV} &= \text{MIN}((\text{Maximum vehicle admissible weight} \\
 &\quad - \text{Vehicle curb mass}_{BEV}); \text{Payload max target}_{BEV})
 \end{aligned}$$

	Maximum admissible weight
Long haul	44 000
Delivery truck	16 000
City bus	19 000
Interurban bus	26 000
Refuse truck	26 000

**Table 7** Vehicle maximum admissible weight considered for simulations.

For person transportation vehicle (city bus and interurban bus) the following payload mass was considered.

For city buses, the low load configuration involves the transportation of 15 passengers, the representative load consists of 42 passengers, and the maximum load accommodates up to 90 passengers. In the case of interurban buses, the low load configuration assumes 30 passengers without any luggage, while the representative load comprises 60 passengers with 15kg of luggage per person. The estimation of payload was calculated based on an average mass of 70kg per person.

### 2.3.4. Simulation hypothesis

Detailed properties of propulsion systems for generic vehicles are outlined in Appendix 2 of the report. Subsequently, the following sections provide focused explanations on fuels, primary powertrain components, and the conditions under which simulations were conducted.

#### 2.3.4.1. Fuel properties

The primary properties of the fuels considered for the vehicle simulations are provided in the table below. These properties are specifically related to parameters that have an impact on energy analysis, including density, lower heating value (LHV), and the Air/Fuel Ratio. Additional attributes such as carbon content and carbon intensity, pertaining to the production of fossil fuels, derivatives, and renewable fuels, are described in the section dedicated to life cycle analysis (LCA).

	Density (kg/m <sup>3</sup> )	LHV (kJ/kg)	AFR (-)
B7	835	42 580	14.39
Gas	0.66	42 700	17.24
H2	0.08	120 000	34.2

**Table 8** Fuel properties for vehicles simulation

#### 2.3.4.2. Propulsion system

##### Engine

Data for internal combustion engines, including performance and efficiency, is sourced either from the IFPEN engine database or the generic engine database within the VECTO tool. This information is utilized to establish the reference for the nominal ICE, specific to a particular energy carrier. Subsequently, for the purpose of sensitivity analysis, the entire nominal efficiency map is uniformly shifted from the peak efficiency to achieve minimum and maximum ICE efficiency values of 40% (min) and 50% (max), respectively.

As an example, the nominal and minimal efficiency ICE definitions are illustrated here for a class 5 Diesel ICE. These definitions include load distribution across a long-haul cycle with the maximum vehicle payload.

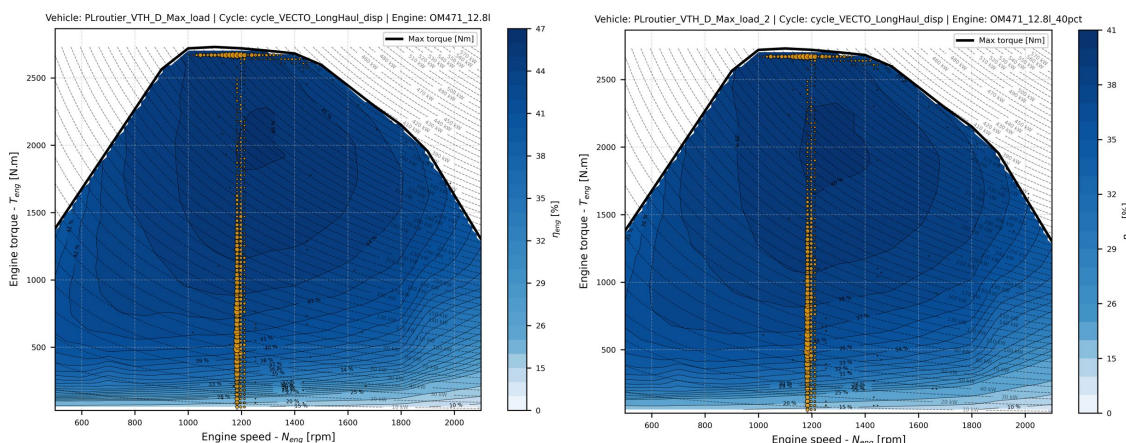

**Figure 15** Class 5 Diesel ICE efficiency and performance

A similar approach was taken for adapting ICE efficiency in the case of CNG and H2 ICE, regardless of ICE performance based on vehicle specifications. The same maximum and minimum peak efficiency values were adopted for ICE; however, the nominal efficiency varies depending on ICE performance, size, and the energy carrier under consideration. Specifically, nominal efficiency is set between 42% and 46% for Diesel ICE, 36% for CNG ICE, and 44% for H2 ICE in terms of peak efficiency.

### Electric motor

Electric motor performance and efficiency map were generated with “Electric motor table generator”, an app tool provided in Simcenter Amesim software to pre-design electric machine. These maps are defined considering a target torque / speed performance for the machine, voltage, and motor typology.

For the electric machine HDVs, a low-speed (5000rpm), high-voltage (800V), interior permanent magnet synchronous machine with water cooling was chosen. This machine is characterized by a peak efficiency of 96% and exhibits symmetrical performance and efficiency maps in both motor and regeneration modes. As an example, the performance and efficiency of this electric machine are illustrated for a class 2 Battery Electric Vehicle (BEV), considering load distribution along a long-haul cycle at a representative vehicle payload.

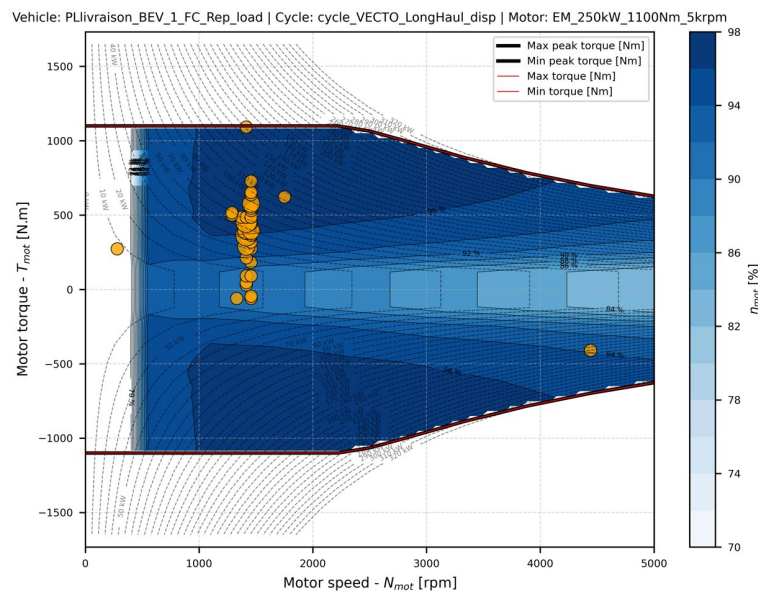

Figure 16 Class 2 BEV Electric machine efficiency and performance

### Battery

Battery performance maps were generated with “Battery pre-sizing” app tool provided in Simcenter Amesim software. These maps are defined considering a pre-calibrated battery cell chemistry type.

For the simulations, a 3.7V generic NMC-C cell was utilized as the fundamental unit for the HDV battery pack. The pack is constructed by assembling these unitary cells in a series arrangement, conforming to an 800V architecture (in alignment with HDV voltage configuration). Additionally, a parallel configuration is employed to achieve the desired storage capacity, contingent upon the specific vehicle type. The nominal pack power is

determined in accordance with the continuous maximum power of the vehicle's electric machine.

The internal resistance (used to estimate battery losses) and the open circuit voltage (OCV) of the entire battery pack are calculated based on the characteristics of the unitary cell, considering the defined pack architecture. For reference, the ohmic resistance and OCV curve of the unitary cell employed in the simulations are provided below.

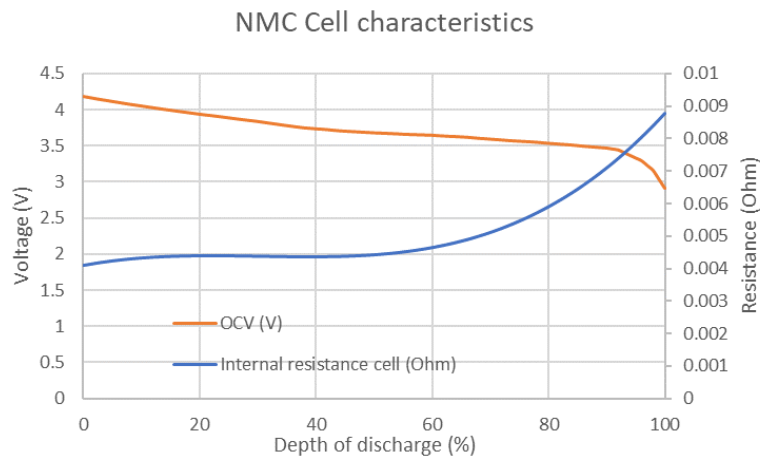

**Figure 17** NMC battery cell characteristic

Battery pack characteristics, derived from the unitary cell, are elaborated in the table below for the various battery packs examined in relation to the tested vehicles. Notably, the simulations do not account for any aging effects on the battery, including State of Health (SOH) and the evolution of internal resistance.

Vehicle	Powertrain	Battery Pack	Assembly
Class 5	HEV	Bat_20kWh_250kW_800V	217S1P
	PHEV	Bat_130kWh_250kW_800V	218S4P
	BEV	Bat_533kWh_350kW_800V	218S15P
		Bat_800kWh_550kW_800V	218S20P
		Bat_1200kWh_550kW_800V	218S30P
FCEV	Bat_100kWh_350kW_800V	218S4P	
Class 2	HEV	Bat_30kWh_250kW_800V	217S1P
	PHEV	Bat_100kWh_250kW_800V	218S4P
	BEV	Bat_400kWh_250kW_800V	244S1P
		Bat_667kWh_350kW_800V	218S15P
		Bat_933kWh_550kW_800V	218S15P
FCEV	Bat_20kWh_250kW_800V	217S1P	
City bus	HEV	Bat_20kWh_250kW_800V	217S1P
	PHEV	Bat_100kWh_350kW_800V	218S4P
	BEV	Bat_533kWh_350kW_800V	218S15P
		Bat_800kWh_550kW_800V	218S20P
	FCEV	Bat_75kWh_250kW_800V	244S1P
Interurban bus	HEV	Bat_25kWh_400kW_800V	217S1P
	PHEV	Bat_100kWh_250kW_800V	218S4P
	BEV	Bat_667kWh_350kW_800V	218S15P
		Bat_933kWh_550kW_800V	218S15P
		Bat_1200kWh_550kW_800V	218S30P
FCEV	Bat_75kWh_250kW_800V	244S1P	
Refuse truck	HEV	Bat_25kWh_400kW_800V	217S1P
	PHEV	Bat_100kWh_350kW_800V	218S4P
	BEV	Bat_400kWh_250kW_800V	244S1P
	FCEV	Bat_75kWh_250kW_800V	244S1P

**Table 9** Battery pack architectures for vehicles

### Fuel cell

The performance and efficiency maps of the fuel cell system are based on data gathered from various light-duty commercial automotive fuel cells measured at IFPEN. In the simulations, a 75kW fuel cell with a peak efficiency of 65% was chosen as the nominal module. Additionally, a 150kW module and a 225kW module (achieved by combining elementary modules) are considered to encompass all vehicle powertrain configurations. In this upscaling process, the nominal module's peak efficiency remains unchanged.

To account for sensitivity, a 55% peak efficiency (min efficiency) and a 70% peak efficiency (max efficiency) were also considered. These values adjust the entire curve, either decreasing or increasing it from the nominal state. The specific efficiencies of the considered fuel cell modules are outlined in the figure below. Notably, the simulations do not incorporate any aging effects on the fuel cell, including power and efficiency losses due to the aging of the active components.

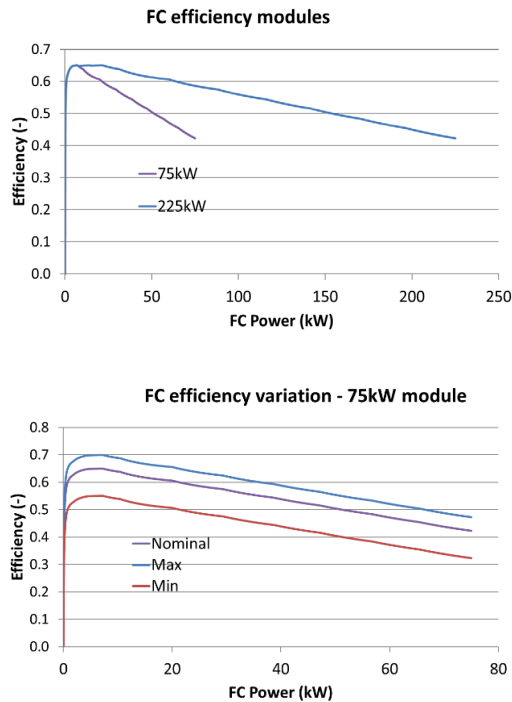

**Figure 18** Fuel cell efficiency for FCEV

**Drivetrain configurations**

For conventional powertrains (ICEVs), Battery Electric Vehicles (BEVs), and Fuel Cell Electric Vehicles (FCEVs), the power machine is connected to the vehicle wheels through a clutch and a gearbox. A dedicated Simcenter Amesim sketch is tailored for each drivetrain configuration. The study encompasses five drivetrain configurations: Conventional ICE Drivetrain, Hybrid Electric Vehicle (HEV) and Plug-in Hybrid Electric Vehicle (PHEV) Drivetrain, BEV Drivetrain, and FCEV Drivetrain. Additionally, a specific drivetrain for Power Take Off (PTO) is included for each drivetrain configuration to accommodate PTO usage in Refuse trucks. This enables the incorporation of an external working profile within a driving profile for each drivetrain type.

The drivetrain typology remains consistent across all vehicle categories. However, the drivetrain characteristics—such as ICE/motor/fuel cell power, gear ratio, battery capacity, and more—are tailored to each vehicle based on specifications outlined in Appendix 2.

In the case of multi-source configurations (xHEV), a parallel hybrid drivetrain is employed. The electric motor is positioned in parallel with the internal combustion engine (ICE) and is coupled ahead of the gearbox. Both machines are connected to the vehicle's front wheels through a clutch and gearbox, transmitting power via the drive shaft. Additionally, two simulation modes must be taken into account to assess fuel consumption: charge-sustaining mode and charge-depleting mode.

In the charge-sustaining mode, the onboard energy management system employs the Equivalent Consumption Minimization Strategy (ECMS) within the vehicle to optimize fuel consumption based on the battery state of charge and the power demand across the driving cycle. In the "charge-sustaining mode," the battery's state of charge (SOC) begins the cycle



- The decision to utilize electric driving, electric assistance, power generation, or driving with ICE is determined solely by comparing the efficiencies along the driving cycle.

In the Fuel Cell Electric Vehicle (FCEV) configuration, the fuel cell and battery are interconnected on the same electric DC bus. The fuel cell employs hydrogen as an energy carrier to supply the required electrical energy for propulsion. A battery is utilized as a buffer to address peaks in energy demands for propulsion, thereby reducing dynamics on the fuel cell, extending its lifespan, and facilitating the recuperation of braking energy. The battery can also function as the primary energy source for vehicle propulsion if storage capacity is limited (in charge-depleting conditions), similar to the xHEV powertrain concept.

The energy management system (ECMS) in the provided sketch and within the onboard vehicle optimizes hydrogen consumption based on the battery state of charge and the power demand throughout the driving cycle. The simulations encompass two scenarios: a "charge-sustaining mode" and a "charge-depleting mode," with the same battery state of charge management approach as observed in xHEVs

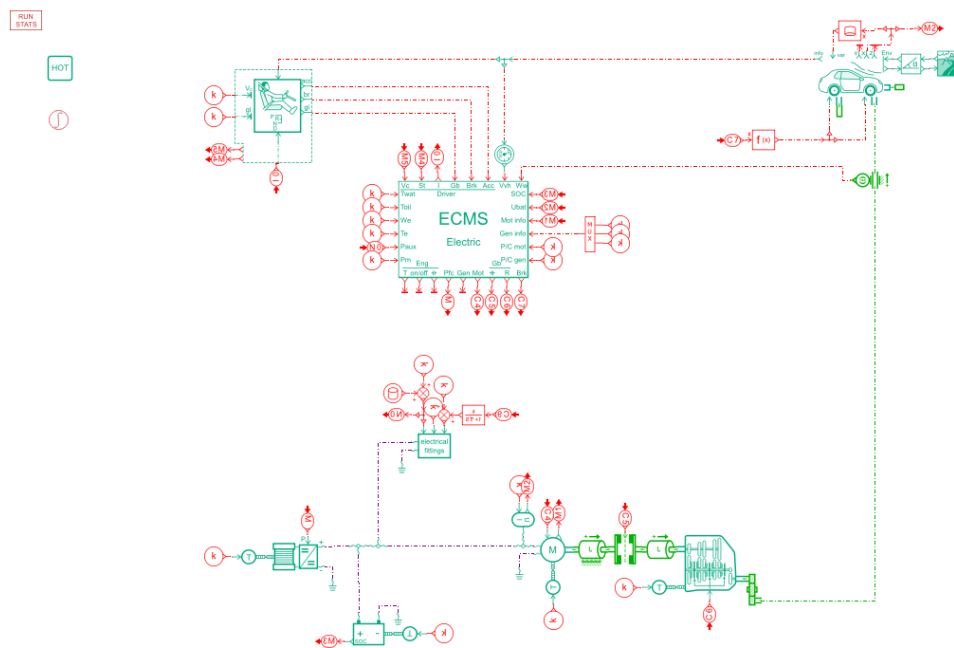

Figure 20 Fuel cell vehicle sketch in Amesim

In the case of a vehicle equipped with Power Take Off (PTO), such as a refuse truck, a working profile is integrated into the driving cycle during multiple stationary phases of the vehicle. For conventional powertrains, mechanical PTO work is derived from the internal combustion engine (ICE) as a mechanical auxiliary. Conversely, for electrified powertrains (including BEVs, FCEVs, and xHEVs), an electrified PTO duty cycle is adopted, with energy collection occurring on the electric DC bus.

In the context of electrified PTO (e-PTO), the mechanical duty cycle provided in VECTO, described in terms of ICE speed and torque, is converted into an electric power duty cycle. This conversion takes into account a generic constant efficiency of 0.9 for the e-PTO converter

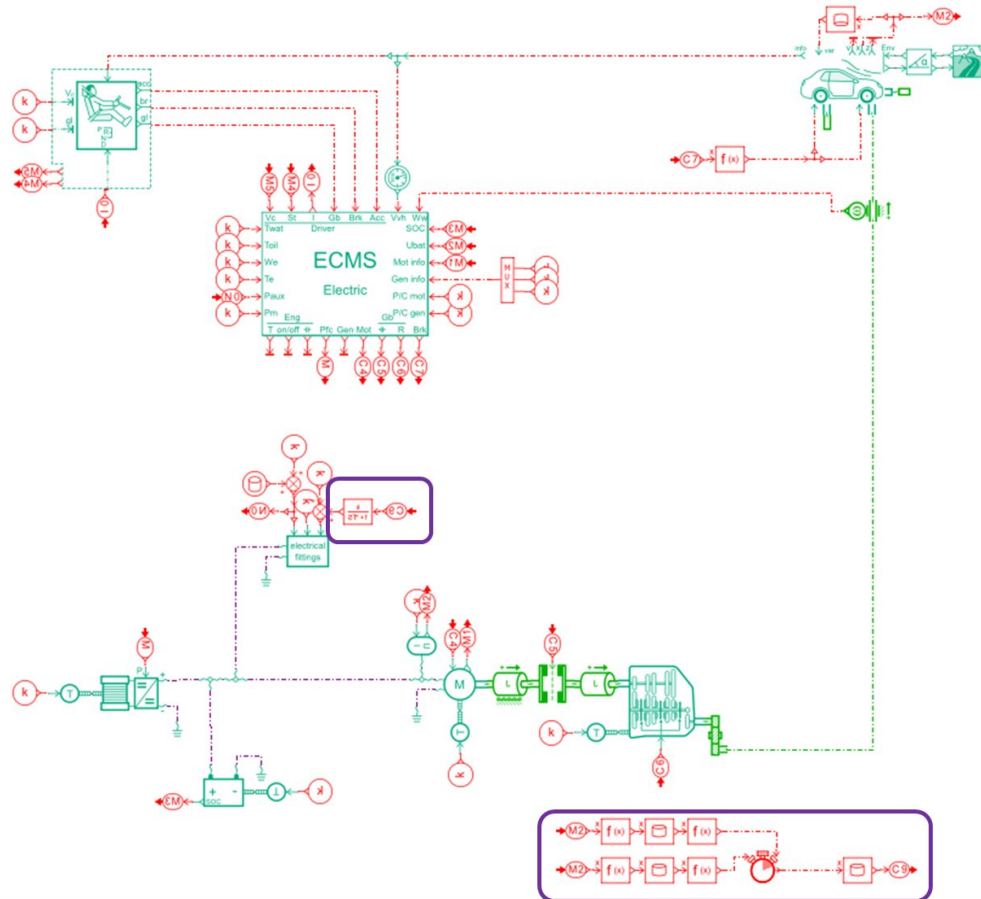
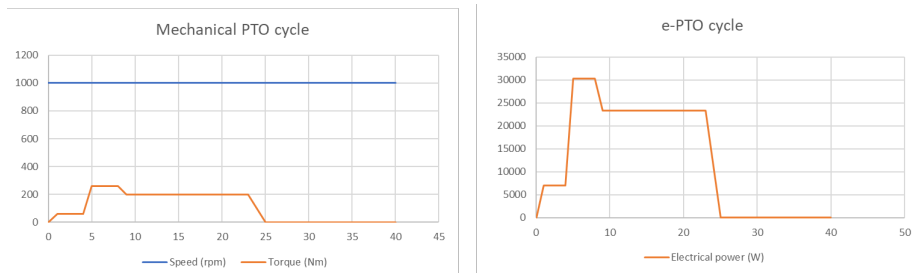

Figure 21 Fuel cell vehicle with PTO sketch in Amesim



**Figure 22** Mechanical and electrical PTO working cycles

#### 2.3.4.3. Temperature condition

In the simulations of vehicles, a consistent ambient temperature of 20°C was set as the nominal condition. For architectures featuring an internal combustion engine, a "cold" start was taken into account, involving additional consumption during the warm-up phase of the ICE. In the case of electrified vehicles (xEV), a temperature regulation of 20°C was maintained for the battery, fuel cell, and electric machine, with performance curves designed for this specific temperature.

The thermal energy management of powertrain components (such as Battery Management Systems for battery or fuel cell cooling) and the energy consumption linked to it were not included or considered within the predefined constant auxiliary load package defined for each vehicle type.

#### 2.3.4.4. Brake recovery and electric losses

xEV are considered with a theoretical maximum 100% brake recovery potential. Recovery is only limited by the electric machine torque in regeneration mode according to the considered speed.

Electrical losses on xEV vehicles have 2 origins:

- internal resistance evolution of battery with its state of charge
- conversion efficiency of inverter added between battery and electric machine

Other losses due to battery charging were not considered in the simulations.

#### 2.3.4.5. Brake recovery and electric losses

Certain vehicles, such as long haul trucks, are commonly fitted with Advanced Driver Assistance Systems (ADAS) functionalities:

- "S&S" (ICE stop when idle at vehicle standstill)
- "Eco-roll" (automatic decoupling ICE from PWT in low slope downhill)
- "Predictive Cruise control -PCC" (utilization of potential derived from accessible preview data of road gradient and the incorporation of a GPS system). For PCC, three modes can be considered:

- crest coasting (uphill) (speed reduction before uphill)
- acceleration without engine power (downhill braking reduced)
- dip coasting (overspeed allowance in downhill)

These Advanced Driver Assistance Systems (ADAS) exert varying impacts on fuel consumption, contingent on the driving cycle. This influence is particularly pronounced in the case of conventional internal combustion engine powertrains, while electrified powertrains exhibit a diminished effect due to their inherent recovery capabilities. Notably, fuel consumption benefits associated with features like Stop & Start (S&S) tend to diminish with electrified powertrains)

In the simulations, ADAS options impact on consumption were evaluated only for long-haul truck and for conventional Diesel powertrain using VECTO tool. The following impact were evaluated considering VECTO cycles and are depicted in the table below.

Cycle	Payload	S&S	Eco-roll	PCC 1/2/3
Long haul delivery	Low	0.4	0	0.4
Long haul delivery	Representative	0	0	1.9
Regional delivery	Low	1.2	0.4	1.2
Regional delivery	Representative	0.6	0	2.0
Urban delivery	Low	2.8	-0.5	0.5
Urban delivery	Representative	2.1	0	0

**Table 10** ADAS effect on fuel saving (%) for long haul truck with ICE powertrain

For other powertrains (xHEV, BEV and FCEV), the ADAS fuel saving potential was not evaluated but estimated from information coming from [JEC, 2020] report for long haul and delivery truck.

All these ADAS effect on fuel consumption are just presented here for information but were not implemented in the life-cycle assessment tool.

Vehicle	Powertrain	Cycle	Payload	Eco-roll + PCC
Long haul truck	HEV/FCEV	Long haul delivery	Low	1
		Long haul delivery	Representative	1.94
	BEV	Long haul delivery	Low	0.5
		Long haul delivery	Representative	0.97
Delivery truck	HEV/FCEV	Regional delivery	Low	1.03
		Regional delivery	Representative	1.44
	BEV	Regional delivery	Low	0.52
		Regional delivery	Representative	0.72

**Table 11** ADAS effect on fuel saving (%) for long haul and delivery truck

## 2.4. SIMULATION RESULTS

### 2.4.1. General status

A multitude of simulations were conducted to account for both nominal conditions and sensitivity analysis across all predefined scenarios. Single-source powertrains such as Internal Combustion Engine Vehicles (ICEVs) and Battery Electric Vehicles (BEVs) yield quick resolution times. However, for multi-source drivetrains such as Hybrid Electric Vehicles (xHEV) or Fuel Cell Electric Vehicles (FCEV), longer simulation durations are necessary to determine the optimal energy pathway throughout the driving cycle, involving the utilization of an energy management system. The latter requires multiple simulations to produce a single simulation result.

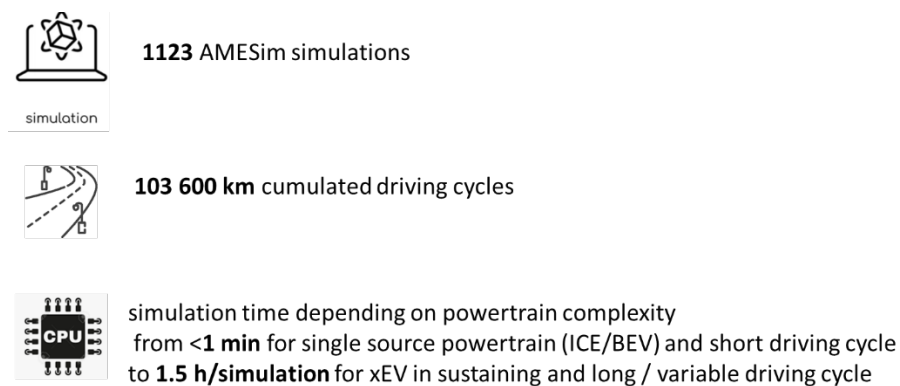

**Figure 23** General status for simulations

### 2.4.2. Main results and comparison with literature

Average fuel consumptions, estimated through simulations while accounting for pertinent mission profile weights, are compared with values from literature. A summary is provided in the tables below, categorized by each vehicle type. Apart from these condensed average consumption figures for vehicle and powertrain configurations, a comprehensive table containing all simulation outcomes was generated. This extensive dataset serves as input for the life-cycle assessment tool.

#### 2.4.2.1. Long haul truck

In the case of long haul trucks, the average energy consumption estimations derived from the EU 2019/1242 regulation profile distribution align well with findings from literature reviews and feedback from manufacturers and operators. Discrepancies from the JEC study [JEC, 2020] emerge due to variations in the average weighted payload and profile utilized for calculations.

For Fuel Cell Electric Vehicle (FCEV) applications, both the low (55%) and nominal (65%) fuel cell peak efficiencies are recorded for average weighted hydrogen (H<sub>2</sub>) estimation. This approach was taken considering the swift maturation evolution of the technology, allowing for comparison with literature.

	Simcenter Amesim simulation	Literature
<b>Long haul truck (class5)</b>	<p><i>Considering average mission profile / load weights</i>            (0% 5-UDL; 3% 5-RDL; 27% 5-LHL)            (0% 5-UDR; 7% 5RDR; 63% 5-LHR)            (From Regulation (EU) 2019/1242, 2019)</p> <p>28.7L/100km (Diesel)            27.7kg/100km (CNG)            9.1kg/100km (H2)            26.2L/100km (HEV)            25.4L/100km (PHEV sustaining mode)            163.2kWh/100km (BEV)            7.3 kg/100km (FCEV)            65% peak FC eff / sustaining mode            8.9kg/100km (FCEV)            55% peak FC eff / sustaining mode</p>	<p>[ICCT, 2023]            33.05L/100km (Diesel)            28.8kg/100km (CNG)            138kWh/100km (EV)</p> <p>[JEC, 2020]            5-LH with 14.3t weighted payload            29.1 / 31.5 L/100km (B7/B100)            27.1 kg/100km (CNG)            27.5L/100km (HEV B7)            0.42MJ/tkm with charge loss (BEV)            7.0kg/100km (FCEV H2)</p> <p>Truck manufacturers communications            8.75kg/100km (Nikola Tre FCEV)            &lt;8kg/100km (Mercedes GenH2)            8.2kg/100km (Kenworth (Toyota) T680 FCEV)            8.75kg/100km (HYLIKO / GreenGT « Hy T44 First Edition)            7.7kg/100km (Quantron QHM FCEV aero)</p>

**Table 12** Long haul truck estimated average consumption vs. review

#### 2.4.2.2. Delivery truck

In the case of Delivery trucks, average energy consumption estimates were derived using the payload-weighted distribution provided by the VECTO 2020 manual profile. While the energy estimations for all powertrain configurations surpass the findings from the JEC study [JEC, 2020] by around around 15%, this can be attributed to variations in the average weighted payload and profile employed in calculations.

For Fuel Cell Electric Vehicle (FCEV) delivery trucks, both the low (55%) and nominal (65%) fuel cell peak efficiencies are considered in calculating hydrogen consumption. This approach accounts for the potential variance in consumption due to the rapidly evolving nature of the technology. It's worth noting that although manufacturer and operator feedback indicates low consumption for FCEV delivery trucks, the specific test conditions outlined in the manufacturer's communications are not described.

	Simcenter Amesim simulation	Literature
Delivery truck (class2)	<p>Considering average mission profile /load weights (15% 2-UDL; 6% 2-RDL; 6% 2-LHL 35% 2-UDR; 24% 2-RDR; 14% 2-LHR) (From VECTO manual, 2020)</p> <p><b>26.5L/100km (Diesel)</b> <b>24.1kg/100km (CNG)</b> <b>7.4kg/100km(H2)</b> <b>19.9L/100km (HEV)</b> <b>19.5L/100km (PHEV sustaining mode)</b> <b>98.9kWh/100km (BEV)</b> <b>4.3kg/100km (FCEV)</b> <b>65% peak FC eff / sustaining mode</b> <b>5.1kg/100km (FCEV)</b> <b>55% peak FC eff / sustaining mode</b></p>	<p>[JRC, 2022] 24L/100km 4-RD (Diesel) 29.1L/100km 4-LH (Diesel)</p> <p>[JEC, 2020] 4-RD with 2.65t weighted payload 22.2 / 23.9L/100km (Diesel B7/ Diesel B100) 20.4L/100km (HEV / B7) 20.2kg/100km (CNG) 18.4kg/100km (HEV / CNG) 1.44MJ/tkm with charge loss (BEV) 4.5kg/100km (FCEV) 4-UD with 2.65t weighted payload 25.1 / 27.2L/100km (Diesel B7/ Diesel B100) 19.3L/100km (HEV / B7) 22.7kg/100km (CNG) 18.4kg/100km (HEV / CNG) 1.41MJ/tkm with charge loss (BEV) 3.7kg/100km (FCEV)</p> <p>Truck manufacturers communications 7.75kg/100km (FC Hyundai xCient 19t carrier)</p>

**Table 13** Delivery truck estimated average consumption vs. review

#### 2.4.2.3. City bus

For city buses, average energy consumption estimates are determined through a combination of assumptions. This includes the distribution of profiles (50% urban dense profile from the VECTO Urban cycle and 50% urban very dense profile from the TFL UIP cycle) as well as payload distribution. For all powertrain configurations, consumption values are compared against the average consumption reported by CATP (French public city bus operator) from a recent measurement campaign involving city bus vehicles with different powertrains [CATP, 2022]. Additionally, the consumption figures are compared to recent communications from bus manufacturers for the Fuel Cell Electric Vehicle (FCEV) powertrain.

It is important to note that variations in driving profiles and assumptions regarding auxiliary load factors (such as HVAC consumption) can significantly impact energy consumption estimations for city buses. Notably, it is observed that the fuel consumption estimations for Hybrid Electric Vehicle (HEV) configurations are underestimated, as indicated by feedback from CATP, particularly in the case of mild hybrid vehicles.

	Simcenter Amesim simulation	Literature
City bus (12m)	<p>Considering average mission profile / load weights (TFL = 50% / Urban = 50% Low load =10% / Rep load= 40% / Max load = 50%) (From IFPEN Proposal)</p> <p>47.5L/100km (ICE Diesel) 42.5kg/100km (ICE CNG) 14.8kg/100km (ICE H2) 27.6L/100km (HEV) 27.7L/100km (PHEV sustaining mode) 121.7kWh/100km (BEV) 6.4kg/100km (FCEV) 65% peak FC eff / sustaining mode 7.6kg/100km (FCEV) 55% peak FC eff / sustaining mode</p>	<p><b>[ICCT, 2023]</b> 55.8L/100km (ICE Diesel) 47.5kg/100km (ICE Gas) 170kWh/100km (BEV)</p> <p><b>[CATP, 2022]</b> 42.9 L/100km (Diesel/HVO) 45.3 kg/100km (CNG) 36.4L/100km (Diesel MHEV) 30.8L/100km (Diesel FHEV) 125 kWh/100 km (BEV) 7.5 - 9.5 kg / 100km (FCEV)</p> <p><b>Bus manufacturers communications</b> 10kg/100km (Van Hool A330 FC 12m) 10.8kg/100km (Solaris Urbino 12 Hydrogen) 6.25/10kg/100km (Mercedes e-Citaro Hydrogen 12m/18m FCEV REX) 8.9kg/100km (IVECO EWAY H2 12m)</p>

*Table 14* City bus estimated average consumption vs. review

#### 2.4.2.4. Interurban bus / coach

For interurban buses, average energy consumption estimates were established using similar assumptions. This includes accounting for profile and payload distribution while focusing on interurban missions characterized by road driving conditions. However, the usage scope extends to include coach operations involving trips on highways.

Average estimated consumption compared with ADEME/IFPEN study for some powertrains / energy carriers shows relevant results [ADEME, 2022]

	Simcenter Amesim simulation	Literature
Interurban bus /coach	<p>Considering average mission profile / load weights (Interurban = 70% / Coach = 30%) Low load =20% / Rep load = 80%) (From IFPEN proposal)</p> <p>33.8L/100km (ICE Diesel) 34.2kg/100km (ICE CNG) 11.1kg/100km (ICE H2) 24.3L/100km (HEV) 24.9L/100km (PHEV) 137.9kWh/100km (BEV) 6.4kg/100km (FCEV) 65% peak FC eff / sustaining mode 6.7kg/100km (FCEV) 55% peak FC eff / sustaining mode</p>	<p>[ADEME, 2022] 34.6L/100km (12m- 16t) (ICE Diesel) 10.5kg/100km (ICE H2) 6.8kg/100km+/-0.5 (FCEV H2)</p>

**Table 15** Interurban bus /coach estimated average consumption vs. review

#### 2.4.2.5. Refuse truck

For refuse trucks, average energy consumption estimates are established through assumptions that consider payload distribution. This includes combining a representative load derived from VECTO with a maximum garbage payload, as applicable to a 26-ton vehicle. These estimations are then compared with findings from a recent study conducted by France Hydrogène mobilité, a French association dedicated to promoting hydrogen mobility. This study focuses on Fuel Cell Electric Vehicle (FCEV) refuse trucks but also provides data on conventional and Battery Electric Vehicle (BEV) applications. Additionally, consumption estimates for FCEV vehicles are compared with information provided by recent communications from refuse truck manufacturers. The comparisons drawn from these assessments highlight relevant and meaningful outcomes.

	Simcenter Amesim simulation	Literature
Refuse truck	<p>Considering average mission profile weights (100% Municipal utility Rep load =50% / Max load = 50%)) (From IFPEN proposal)</p> <p>72.1L/100km (ICE Diesel) 71.8kg/100km (ICE CNG) 25.6kg/100km (ICE H2) 56.8L/100km (HEV) 58L/100km (PHEV) 235.5kWh/100km (BEV) 13kg/100km (FCEV) 65% peak FC eff / sustaining mode 15.6kg/100km (FCEV) 55% peak FC eff / sustaining mode</p>	<p><b>[France Hydrogène mobilité, 2023]</b> 75L/100km (ICE Diesel) 75kg/100km (ICE Gas) 220kWh/100km (BEV) 17kg/100km (FCEV)</p> <p><b>Refuse truck manufacturers.</b> 12.5kg/100km ((Hyzon refuse FC) 19t 12.5kg/100km (DAF FCEV H2 - HECTOR) 16.6kg/100km (Mercedes - HECTOR)</p>

**Table 16** Refuse truck estimated average consumption vs. review

### **3. LIFE-CYCLE ASSESSMENT**

#### **3.1. INTRODUCTION**

The objective of this part is to determine the GHG emission factors that will be used in the simulator. Three categories of emission factors are considered: fuel emission factors, carbon intensity of the electricity mix and emission factors associated with vehicle production and recycling (for chassis, tires and battery). For the latter, in the interactive tool, there are sometimes cursors which will allow the user to choose his hypothesis. Nevertheless, reference values from this section will be presented (such as for example for the emission factor of battery production).

These emission factors were obtained using the life cycle assessment methodology. LCA was performed in accordance with ISO 14040 & 14044 standards. The functional unit is  $\text{gCO}_2\text{eq/tons.km}$ , where the tons refer to the payload of the vehicle, and not to the total mass of the vehicle.

#### **3.2. FUEL EMISSION FACTORS**

The use of fuels can entail direct greenhouse gases emissions. However, in order to assess the life-cycle impact of fuel use, it is necessary to also consider the production and supply phases. Therefore, fuel emission factors are generally subdivided in two categories: Well-to-Tank (WTT) for the production and supply phases, and Tank-to-Wheel (TTW) for the use phase. The addition of these contributions is the emission factor of the fuel on its entire life cycle and is usually denoted as Well-to-Wheel (WTW).

For some fuels, such as biofuels or electro-fuels (also called e-fuels), carbon dioxide is captured either in the biomass used to produce the fuel, or in the air or in flume gas stacks. This means some credits (so called recycled  $\text{CO}_2$ ) can be applied to the emission factors of these fuels.

Finally, it is sometimes possible to blend different fuels, like fossil diesel blended with biodiesel in B7 or B30. Emission factors of such blends can be calculated from the known composition.

##### **3.2.1. Tank-to-Wheel emissions**

Tank-to-Wheel emissions are generated by the combustion process within the energy converter (engine, fuel cell) that converts fuel energy into  $\text{CO}_2$  emissions. All greenhouse gases must be considered to properly compute the total GHG emissions. This includes for example  $\text{N}_2\text{O}$  and  $\text{CH}_4$ , that are powerful GHG, although they are emitted in limited quantities. Based on literature review, the contribution of  $\text{N}_2\text{O}$  and  $\text{CH}_4$  regarding  $\text{CO}_2\text{eq}$  emissions represents around 6.6% of  $\text{CO}_2$  exhaust emissions for diesel fuelled-trucks (essentially from  $\text{N}_2\text{O}$  emissions which are approximately  $50 \text{ gCO}_2\text{eq/km}$  [ICCT, 2023]) and 2.5% of  $\text{CO}_2$  exhaust emissions for CNG fuelled-trucks (essentially from  $\text{CH}_4$  emissions which are approximate  $500 \text{ mg/kWh}$  [Concawe 6/20]), considering a 100-year global warming potential. For ICE- $\text{H}_2$  fuelled-trucks, It is assumed that the after-treatment system and the  $\text{N}_2\text{O}$  question are considered similar to those for diesel-fuelled trucks, pending the availability of comprehensive experimental data to substantiate this assumption.

##### **3.2.2. Well-to-Tank emissions**

Well-to-Tank takes into account all the emissions generated during production, transport, and distribution of the different fuels. For example, ethanol can be produced from

different feedstocks, like wheat or sugarcane. The production of wheat differs from the production of sugarcane, and therefore the WTT emission factor of ethanol from wheat is not the same as that of ethanol from sugarcane.

For further details, please consult JEC v5 reports [JEC, 2020].

For e-fuels (green H<sub>2</sub>, e-diesel, e-methane), the emission scope is extended with upstream emission from infrastructure needed to produce them (mainly solar panels and wind turbines). See Concawe report 17/22 for further details. It was observed that infrastructure requirements (per unit of energy produced) are significantly higher for e-fuels than for fossil fuels and biofuels, and could not reasonably be neglected for e-fuels. Hence, the reason why they are considered.

### 3.2.3. Recycled carbon dioxide

The emissions associated with recycled carbon dioxide are also called biocredits. Biocredits relate to the share of CO<sub>2</sub> offset which occurs during the production of the fuel and that results in a closed-loop carbon cycle: e.g. for biofuels the CO<sub>2</sub> captured by biomass from the air when it grows; or for e-fuels the CO<sub>2</sub> captured from the air via Direct Air Capture. Biocredits do not account for the energy and utilities necessary for carbon capture, for example, because this is already accounted for in the WTT emission factor.

The share of renewable energy in transport fuels continuously increases, from 2% in 2006 to 5.75% in 2011 (see text 2003/30/CE), to 10% in 2020 (see text 2009/28/CE). It is expected to increase to 14% in 2030 (see text 2018/2001). The last recast of the renewable energy directive currently proposes that the renewable energy reduces by at least 13% the GHG emissions of transport fuels (compared to a fossil reference), which should lead to a share of renewable energy beyond the current target of 14%.

### 3.2.4. Fuel blends

Emission factors of fuel blends are calculated based on the energy content of each fuel in the blend. Indeed, knowing the density, the energy content and the emission factors of two fuels and their volumetric proportions in a blend enables to directly compute the emission factors of that blend.

### 3.2.5. Study limitation related to fuels

The following aspects are not considered in this instance as they are not included in the scope of the JECv5 report used to establish emission factors for fuel: fuels and related resources availability, emissions due to direct and indirect land use change and water / material consumption for fuels production, etc. Further work extending into these sensitivities would be valuable.

## 3.3. CARBON INTENSITY OF THE ELECTRICITY MIX

BEVs use electricity as primary energy carrier. Therefore, the GHG emissions per kWh of electricity consumed must be computed to have a proper life-cycle impact of the energy consumption of BEVs. In this study, the carbon intensity of the electricity is set by the user of the web application.

However, a reference is provided to guide the user into choosing appropriate values depending on the situation to be assessed. One key update involved revising the source of reference values for the carbon intensity of electricity used during the vehicle propulsion phase (battery charging). This is applicable to the BEV, PHEV and CEV vehicle categories.

These values are expected to evolve over time, driven by factors such as meteorological variability in Europe along with the ratio of installed renewable electricity generation capacity. For the comparators, it was essential to rely on data that was recent and established in a transparent, and scientifically grounded manner.

Previously, the reference values were derived from the work conducted by the Joint Research Centre (JRC), as detailed in their publication [Scarlat, 2022]. While this work provided a robust framework, it relied on data from 2019, which has become outdated given the rapid pace of change in electricity generation and consumption patterns across Europe.

To address this evolving need, the ElectricityMaps service was adopted as the new reference source. This platform provides constantly updated carbon intensity data for European countries, with the exception of Malta, and ensures transparency by adhering to a Life Cycle Assessment (LCA) methodology [ElectricityMaps, 2025]. Using ElectricityMaps, the comparators now reflect 2024 values for electricity carbon intensities. These values have been used to determine the European average default value for the use phase emission intensity, but the comparator also allows the user to manually enter the value of any specific country or scenario within the range.

The updated reference values are clearly documented and presented to comparator users in a dedicated page, which explains the role of electricity carbon intensity in calculating the environmental footprint. This page is particularly helpful for new users, providing a clear understanding of how the reference values inform scenario comparisons.

The default value for the slider controlling electricity carbon intensity in the dashboards has been set to the average carbon intensity of EU countries (with the exception of Malta, reflecting a transparent baseline for comparisons). With the updated reference, this average value has decreased by 24% from 335 to 254 gCO<sub>2</sub>eq/kWh. This adjustment reflects the overall decarbonization of the European electricity grid and enhances the accuracy of the dashboards in representing current conditions.

### 3.4. EMISSION FACTORS DUE TO VEHICLE PRODUCTION

The objective is to determine the GHG emission factors of the various vehicle components: chassis, tyres, battery, fuel cell, electric motor, internal combustion engine and tanks. In earlier versions of the comparators, these emission factors were obtained using the life cycle analysis methodology performed in accordance with ISO 14040 & 14044 standards using commercial LCA software SimaPro®. The database used is Ecoinvent v.3.8.

This revision utilizes the PREMISE LCA framework [Sacchi, et al., 2022] developed by the Paul Scherrer Institute (PSI), which draws on Ecoinvent v3.9.0 data. PREMISE integrates detailed life cycle inventories for European material production, energy use, and electricity mix. It explicitly models the production of key vehicle components, such as the chassis, powertrain, and energy storage systems, assuming European manufacturing conditions. Furthermore, it includes end-of-life (EOL) phases, enabling a more robust and context-specific evaluation of environmental impacts.

The HDV comparator now assumes that the production of these components occurs within Europe, which PREMISE incorporates into its calculations. This represents a significant evolution, as previous IFPEN modeling assumed vehicle production took place in Asia. The analysis accounts for European production processes and EOL phases, providing a comprehensive understanding of environmental impacts. The functional unit for the HDV tool is expressed as gCO<sub>2</sub>eq/tkm, where "tons" refer to the payload of the vehicle rather than its total mass.

This update demonstrates the coherence between the PC and HDV comparators, as both now rely on PREMISE models to cover vehicle production aspects. By assuming a European production context for components and the chassis, the tools ensure alignment with regional production processes, material sourcing and energy mix, delivering results that are highly relevant for European stakeholders. This consistency allows for more accurate and reliable comparisons of the environmental impacts associated with different propulsion technologies.

The following section present the hypothesis the emission factors used for estimating the CO<sub>2</sub> equivalent emissions of vehicle components.

### 3.4.1. Chassis

For the emission factors related to the production of the chassis of internal combustion (and hybrid) vehicles, the Ecoinvent data “Bus production {RER}| producing” has been used and adapted (depending on the type of vehicles). For the interurban bus, the modeling of the chassis is derived from that of the bus (mass difference). Some differences in interior composition were also accounted for, namely the additional steel seats (Yuce, C, 2014).

For the emission factors of the chassis of electric vehicles and FCEVs, we consider a material percentage adjusted in relation to the chassis of internal combustion vehicles.

The end-of-life scenario for chassis is modeled from the PE International and Ginkgo21 report for ADEME. Most of the rates provided concerning the proportion of recycling, incineration, landfilling by type of material have been reused.

The 2000/53/EC directive of the European Parliament and of the Council relating to end-of-life vehicles (ELV) has also been followed. An ELV collection rate of 69% was used. The distances from the holder to the demolisher then from the demolisher to the crusher have also been taken into account.

### 3.4.2. Tyres

The weight and composition of coach and truck tires are based on the JRC's IMPRO CAR I report “Environmental Improvement of Passengers Cars”. Tire life is assumed to be 40,000 km.

The end-of-life scenario for tires is based in part on a study carried out for ADEME entitled “Transport and logistics of waste” published in October 2014. The tire collection rate is assumed to be identical to that of ELVs, as are the logistical characteristics related to their transport to the various sites. The same waste statistics were used to model the share of materials going to incineration or landfill.

The following table presents the emission factors used for tires CO<sub>2</sub>eq emissions :

Application	Tyres Emission Factor [tonsCO <sub>2</sub> eq/kg]
class 5	34,0
class 2	8,4
city bus	10,9
interurban bus	10,9
refuse truck	8,4

*Table 17 Tyres emission factor*

### 3.4.3. Powertrain

For the emission factors of thermal and electric motors, data from the PREMISE framework was used.

The fuel cell consists of a modular 75 kW pack. One to three packs are planned, depending on the vehicle category.

Three efficiency levels are planned for the fuel cell: a nominal peak efficiency of 59% (state of the art for heavy-duty vehicles), a maximum peak efficiency of 6% (current state of the art for light-duty vehicles), and a future peak efficiency of 70% (for the maximum trend). For the fuel cell, a system energy of 6000 W/kg is used for mass estimation, based on the DOE Hydrogen and Fuel Cell Program Report (2020). The impact of the hydrogen tank mass on the vehicle mass is also considered, with a density of 60 g H<sub>2</sub>/kg representative of a Type IV tank (350 or 700 bar).

For the fuel cell, a power output of 225 W/cell was assumed (IFPEN assumption). The fuel cell modeling is based on the studies by [Evangelisti, 2017] and [Miotti, 2017] for bipolar plates. Regarding the fuel cell's auxiliary equipment, the study by [Stropnik, 2019] was used. For platinum, an emission factor of 69,500 kgCO<sub>2</sub>-eq/kg is considered (ecoinvent: platinum market (GLO)). This leads to an estimated emission factor of 40 kgCO<sub>2</sub>-eq/kW for the fuel cell as a whole, the default value of the corresponding slider.

### 3.4.4. Tank

For diesel tank modeling we consider 50% Steel, Low Alloy and 50% Aluminum, Cast Alloy (GRDF, DEDIEU François 2019).

For GNV Type IV tank we consider 45% epoxy resin, 55% carbon fiber (Pranjali Sharma, 2021) ("Study to methodize the design of a safe Type-4 CNG storage vessel using finite element analysis with experimental validation" International Journal of Pressure Vessels and Piping).

The amount of H<sub>2</sub> transported in the vehicles can be modified. This parameter impacts the estimated vehicle range (visible by hovering the mouse over the graph bar). It also impacts the emissions associated with the carbon fiber tank, whose emission factor can also be modified using a slider (25 kgCO<sub>2</sub>eq/kg<sub>tank</sub> is defined as the default value according to IFPEN's LCA modeling). It was assumed that 26.3 kg of tank are required to store 1 kg of H<sub>2</sub>.

For the modeling of the H<sub>2</sub> type IV tank, the main reference is the Ademe Sphera study published in 2021. This tank can contain a maximum of 5.1 kgH<sub>2</sub> at 700 bar.

The following table presents the emission factors used for tanks CO<sub>2</sub>eq emissions:

tank type	Tank capacity [kg]	Tank mass empty [kg]	Emission Factor [kgCO <sub>2</sub> eq/kg_tank]
type I - 200bars	16	93	5,8
type IV - 500bars	8	210	22,8
LNG tank steel	115	320	10,0
diesel steel tank	418	500	3,2

**Table 18** Tanks emission factors

### 3.4.5. Battery

Battery production GHG intensity is mostly related to material extraction and production process. In the tool provided with this report, the user can set the GHG intensity of the production of 1 kWh of battery. The following gives some references to help the user chose relevant values.

[Aichberger, 2020] analysed 50 publications from the years 2005-2020 about life cycle assessment (LCA) of Li-ion batteries to assess the environmental effects of production, use, and end of life for application in electric vehicles. For battery production emissions, the median value was 120 kgCO<sub>2</sub>eq/kWh.

However, given the dynamic nature of the sector, it is important to consider technological, geographical, and environmental developments in battery production, that tend to reduce the emission factor of this key component. [Xu, 2022] builds a prospective life cycle assessment model for lithium-ion battery cell production for various chemistries, production regions and time frames. This work provides relevant values for current and future batteries in different contexts. These emission factors are summarized in the table to guide the user in the choice of this tool parameter Reflecting current market trends, where Nickel Manganese Cobalt (NMC) batteries produced in China dominate production, the default emission factor for both tools has been updated to 78 kgCO<sub>2</sub>eq/kWh.

	LFP-Graphite			NMC-Graphite / NCA-Graphite		
	China	United States	European Union	China	United States	European Union
2020	69	49,5	39,5	86	65	52
2030	56	40	34	70	52	45
2040	45	32	28	58	42	37
2050	34	24	19,5	44	32	27

**Table 19** CO<sub>2</sub>eq emission factors for battery production for different chemistries, regions and timelines extracted from [Xu, 2022]

In addition, to promote transparency and user comprehension, both tools now explicitly display the contribution of battery production within total vehicle life cycle emissions. This is visually represented through yellow segments in the emission bar charts, allowing users to easily identify and assess the relative impact of battery manufacturing.

Nonetheless, a slider remains available for users to adjust the battery production emission factor. This flexibility is essential due to the high variability of emissions based on geographic, technological, and industrial factors. For example, current challenges in scaling up battery production in Europe illustrate the ongoing changes in this sector. Retaining this adjustable parameter ensures that both comparators remain responsive to emerging data and industry developments.

## 4. CONCLUSIONS

This report is the supporting document to the [life-cycle assessment tool for heavy-duty vehicles](#) (HDVs) developed by IFP Energies nouvelles and commissioned by Concawe that was published in July 2023, and updated in 2026. It describes the simulation background behind the tool.

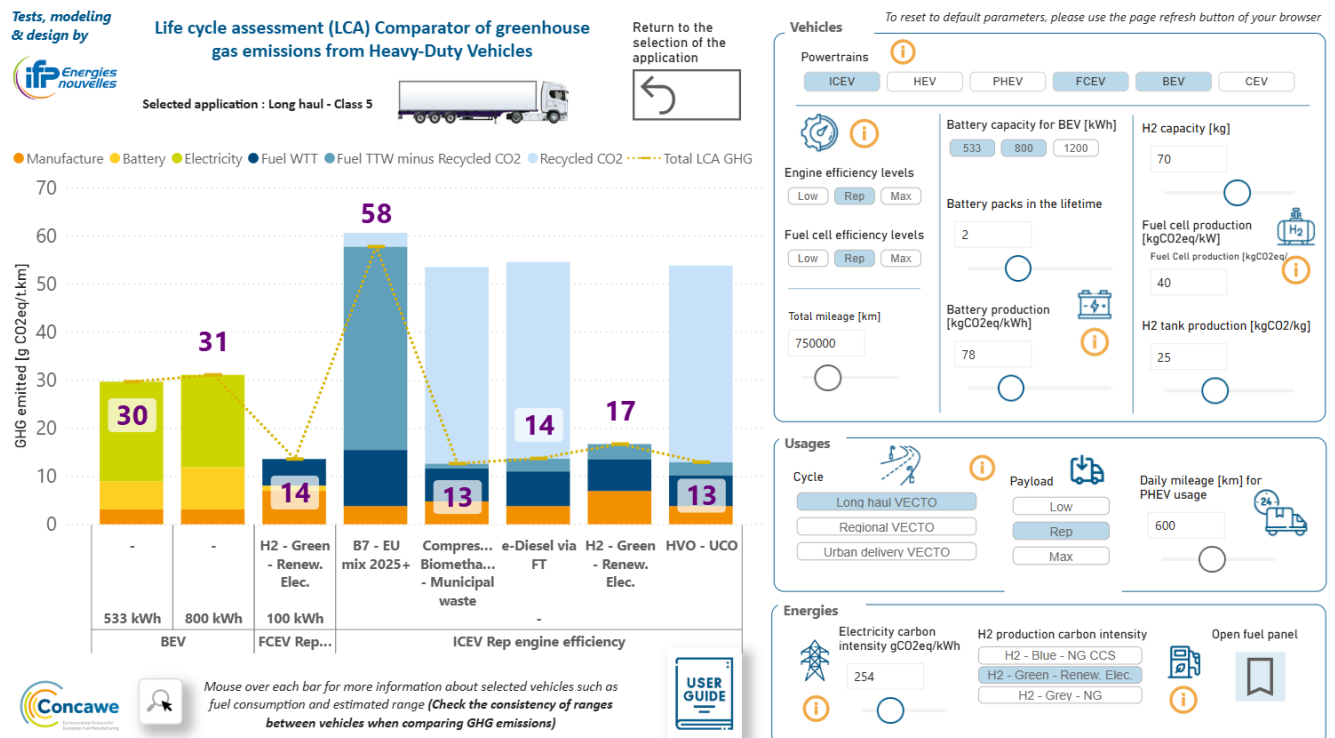

Transport related GHG emissions represent approximately a quarter of the European Union (EU) greenhouse gases (GHG) emissions, out of which commercial road transport represents approximately a third of this. In the context of aiming at reaching carbon neutrality in 2050, reducing heavy-duty transport related GHG emissions is an important factor.

Several technologies can contribute to heavy duty transport decarbonisation: Battery Electric Vehicles (BEVs, or their derivative, Catenary Electric Vehicles (CEVs)), Internal Combustion Engines Vehicles (ICEVs) running on low-carbon fuels (renewable diesel, renewable gas, low-carbon hydrogen), hybridized (Hybrid Electric Vehicles (HEVs), Plug-in Hybrid Electric Vehicles (PHEVs)) and Fuel Cell Electric Vehicles (FCEVs). Understanding the benefits and drawbacks of each solution from a life-cycle perspective for a given use case is difficult. The tool aims at improving this understanding and help decision making.

HDVs have numerous vehicles categories, use cases, have access to many powertrain and energy carrier combinations. The tool allows to combine the following parameters to define specific use cases:

- 7 Powertrains and their efficiencies: ICEV (fuelled by diesel or diesel-like fuels, gas (compressed (CNG) or liquefied (LNG)) or hydrogen), HEV, PHEV, FCEV and BEV (and CEV);

- 5 Vehicle categories: Long-haul truck (Class5), delivery truck (Class2), city bus, coach, and refuse truck (for garbage collection);
- 5 categories of energy carriers: Diesel (fossil-based and derivatives such as B7, B30, B7+25%HVO), Diesel-like fuels with renewable characteristics (including HVO, B100 (100% FAME), e-Diesel, biomass-to-liquid, etc.), hydrogen (grey, blue or green), CNG and LNG (fossil-based, bio-based, e-fuel based), and Electricity (with variation on carbon intensity);
- Battery, fuel cell and hydrogen tank capacity and production emissions;
- Number of battery packs used in the lifetime of the vehicle;
- Use cases (payload, trip profile, charging frequency)

Vehicle simulations were developed using Simcenter Amesim™ software. First, the simulations were calibrated using the “VECTO” tool (simulator for HDVs developed by the European Commission) on the “mainstream” ICEV configurations: this showed a good fit, with a less than 2% difference on fuel consumption on typical driving cycles. Then, the simulations were expanded to alternative powertrains (HEV, PHEV, FCEV, BEV). The vehicles configurations (powertrain characteristics, weight, efficiencies, battery capacity, etc.) and their conditions of use (driving cycles, payload) were selected based on a literature review of existing vehicles. The simulations results (energy consumptions) were cross-checked with data found in the literature and showed an adequate consistency considering that the driving cycles used in the literature may vary and are not always described. Eventually, the vehicles simulations provide an energy consumption (expressed in L/100km, kg/100km or kWh/100km) for each vehicle configuration featuring the combined parameters mentioned above.

This energy consumption is translated in CO<sub>2</sub>eq emissions using the emission factors (tank-to-wheel, well-to-tank and recycled CO<sub>2</sub> contributions) of the different energy carriers (liquids, gas and electricity). On top of that are added the exhaust non-CO<sub>2</sub> emissions (CH<sub>4</sub> and N<sub>2</sub>O contributions, that are powerful GHG, even if emitted in small quantities) and the emissions of manufacturing the vehicle (powertrain, chassis, battery, tank, tires), allowing to obtain the life-cycle emissions of the vehicles expressed in gCO<sub>2</sub>eq/t.km (where “t” are the tons of goods transported).

An extensive use of this LCA tool for HDVs shows that the optimal options for decarbonization are highly dependent on the use case considered.

## 5. GLOSSARY

B7: Diesel with 7% bio

BEV: Battery Electric Vehicle

CEV: Catenary Electric Vehicle

CNG: Compressed Natural Gas

ECMS: Equivalent Consumption Minimization Strategy

FCEV: Fuel Cell Electric Vehicle

HVAC: Heating, Ventilation and Air-Conditioning

HDV: Heavy Duty Vehicle

H<sub>2</sub>: Dihydrogen

HEV: Hybrid Electric Vehicle

ICEV: Internal Combustion Engine Vehicle

LCA: Life Cycle Analysis

LDV: Light Duty Vehicle

LHL: Long Haul cycle at Low load

LHR: Long Haul cycle at Representative load

MDV: Medium Duty Vehicle

NMC: Nickel-Manganese-Cobalt base lithium battery

PCC: Predictive Cruise Control

PHEV: Plug-in Hybrid Electric Vehicle

PTO: Power Take Off

RDL: Regional Delivery at Low load

RDR: Regional Delivery at Representative load

RRC: Rolling Resistance Coefficient

S&S: Stop and Start

SOC: State Of Charge

SOH: State Of Health

TTW: Tank To Wheel



UDL: Urban Delivery cycle at Low load

UDR: Urban Delivery cycle at Representative load

VECTO: Vehicle Energy Consumption Calculation Tool

WTW: Well To Tank

## 6. REFERENCES

1. [ICCT, 2023] A comparison of the life-cycle greenhouse gas emissions of EU Heavy duty vehicles and fuels
2. [JRC, 2022] CO2 emissions of the European heavy duty vehicle fleet
3. [JEC, 2020] JEC Tank-To-Wheels report v5: Heavy duty vehicles “Well-to-Wheels analysis of future automotive fuels and powertrains in the European Context”
4. [ICCT, 2021] CO2 emissions from trucks in the EU: An analysis of the heavy-duty CO2 standards baseline data
5. [ADEME, 2022] « TRANPLHYN » transport lourds fonctionnant à l’hydrogène
6. [Pardhi, 2022] A Review of Fuel Cell Powertrains for Long-Haul Heavy-Duty Vehicles: Technology, Hydrogen, Energy and Thermal Management Solutions -Energies
7. [CATP, 2022] Etude comparative sur les différentes motorisations des autobus
8. [MTSE, 2018] Analyse coûts bénéfiques des véhicules électriques - Les autobus et autocars
9. [Argonne, 2014] Status of Hydrogen Fuel Cell Electric Buses Worldwide
10. [ABERDEEN, 2021] HECTOR Project - ‘Hydrogen waste collection vehicles in Northwest Europe - Interreg EU
11. [Roland BERGER, 2021] Fuel\_cells\_hydrogen\_trucks
12. [ADEME, 2018] Bilan transversal de l’impact de l’électrification par segment E4T
13. [JRC, 2020] Assessment of on-road emissions of refuse collection vehicles
14. [Sandhu, 2021] Real-world activity, fuel use, and emissions of heavy-duty compressed natural gas refuse trucks
15. [France Hydrogène mobilité, 2023] Guide de la benne à ordures ménagères électrique à hydrogène
16. <https://www.automobile-propre.com/>
17. HD vehicle manufacturers website (MAN, DAIMLER, VOLVO, SCANIA, HYZON...)
18. [JEC, 2020] Prussi, M., Yugo, M., De Prada, L., Padella, M., Edwards, R. and Lonza, L., *JEC Well-to-Tank report v5*, EUR 30269 EN, Publications Office of the European Union, Luxembourg, 2020, ISBN 978-92-76-19926-7, doi:10.2760/959137, JRC119036.
19. [Concawe, 2022] Concawe, Aramco, E-Fuels: A techno-economic assessment of European domestic production and imports towards 2050 (Concawe Report 17/22)
20. [Scarlat, 2022] Scarlat, N.; Prussi, M.; Padella M. *Quantification of the carbon intensity of electricity produced and used in Europe*; Applied Energy, Volume 305, 2022.

21. [Aichberger, 2020] Aichberger, C.; Jungmeier, G. *Environmental Life Cycle Impacts of Automotive Batteries Based on a Literature Review*. *Energies* 2020, 13, 6345. <https://doi.org/10.3390/en13236345>
22. [Xu, 2022] Xu, C., Steubing, B., Hu, M., Harpprecht, C., van der Meide, M., Tukker, A. (2022). *Future greenhouse gas emissions of automotive lithium-ion battery cell production*. *Resources, Conservation and Recycling*, 187, 106606. ISSN 0921-3449. <https://doi.org/10.1016/j.resconrec.2022.106606>.
23. [Evangelisti, 2017] Evangelisti, S., Tagliaferri, C., Brett, D., Lettieri, P., *Life cycle assessment of a polymer electrolyte membrane fuel cell system for passenger vehicles*, *Journal of Cleaner Production*, Volume 142, Part 4, 2017, Pages 4339-4355, ISSN 0959-6526, <https://doi.org/10.1016/j.jclepro.2016.11.159>.
24. [Miotti, 2017] Miotti, M., Hofer, J. & Bauer, C. *Integrated environmental and economic assessment of current and future fuel cell vehicles*. *Int J Life Cycle Assess* 22, 94-110 (2017). <https://doi.org/10.1007/s11367-015-0986-4>
25. [Stropnik 2019] Stropnik R., Lotrič A., Bernad Montenegro, A., Sekavčnik, M., Mori, M. *Critical materials in PEMFC systems and a LCA analysis for the potential reduction of environmental impacts with EOL strategies*. *Energy Sci Eng.* 2019;7:2519-2539. <https://doi.org/10.1002/ese3.441>
26. [ElectricityMaps, 2025] Electricity Maps, 2025. *Methodology for the electricity mix and derived signals*, Electricity Maps, [Online] Available at: <https://www.electricitymaps.com/> [Accessed 2024].
27. [Sacchi, et al., 2022] Sacchi, R. et al., 2022. *PROspective EnvironMental Impact asSEment (premise): A streamlined approach to producing databases for prospective life cycle assessment using integrated assessment models*. *Renewable and Sustainable Energy Reviews*.

## 7. APPENDIX

### 7.1.1. Appendix 1: Vehicle / powertrain review from literature

In this part of the report, a review on vehicle and powertrain characteristics is presented for the five vehicle categories defined in the simulation study. The objective of this review is to help defining reference generic vehicles and powertrains for the vehicle simulation process.

#### 7.1.1.1. Long haul truck

##### *Vehicle specifications*

JRC defines 2 types of class 5 truck with dedicated vehicle specificity: 5-RD dedicated to “regional delivery.” and 5-LH dedicated to “long haul mission.” [JRC, 2022]

Average and best in class vehicle specifications are proposed for these vehicles.

	Average 5-RD	Average 5-LH	Best in class 5-RD	Best in class 5-LH
CdxA (m2)	6.62	5.63	4.79	4.48
Curb mass (kg) (no body/trailer)	7093	7747	6548	7118
Rolling Resistance Coefficient - RRC (kg/t)	Axle 1: 5.6 Axle 2: 6.2	Axle 1: 5.2 Axle 2: 5.7	Axle 1: 4.7 Axle 2: 5.0	Axle 1: 4.0 Axle 2: 4.0
Average payload (kg) EU 2019/1242,2019	10260	13840	10260	13840

**Table 20** Class 5 truck specifications from JRC

JEC Wheel to Tank report V5 propose most common (not average!) specifications in the fleet of the class 5 truck for model year 2016 and 2025. Model year 2025 specifications are estimated considering a 1.1%/year CO2 reduction prevision. [JEC, 2020]

	Model year 2016	Model year 2025
CdxA (m2)	5.57	-0.61
Curb mass + trailer mass (kg)	7550+7500	-200
Rolling Resistance Coefficient - RRC (kg/t)	Axle 1: 5.0 Axle 2: 5.5	-1%
Average payload (kg)	Low: 2600 (30% ICE / 37.2% for BEV) Rep : 19300 (70% ICE / 62.7% for BEV)	

**Table 21** Class 5 truck specifications from JEC Wheel to Tank report V5

IFPEN/ADEME in Tranplhyn 2022 studies define an average long-haul truck for fuel evaluation as followed [ADEME, 2022]

	Long haul truck
CdxA (m2)	5.7
Curb mass (kg)	13728 (ref Diesel)
RRC (kg/t)	6
Payload (kg) Distribution (%)	Low: 0 (2% 5-UDL; 3% 5-RDL; 24% 5-LHL)  Rep: 19000 (4% 5-UDR; 7% 5-RDR; 60% 5-LHR)

**Table 22** Class 5 truck specifications from IFPEN/ADEME

### Powertrain specifications

#### Conventional ICE Powertrain

JRC define the average class 5 truck ICE powertrain for the 2 types of class 5 truck:

5-RD truck with powertrain dedicated to “regional delivery” and 5-LH truck with powertrain dedicated to “long haul” [JRC, 2022]

Average and best in class ICE specifications are proposed. This is mainly Diesel DI powertrain and 8.5% CNG for 5-RD subgroup.

	Average 5-RD	Average 5-LH	Best in class 5-RD	Best in class 5-LH
Gear nb. (-)	12	12	12	12
Last gear ratio (-)	0.97	0.99	same	same
Axle ratio (-)	2.94	2.53	same	same
Axle eff (%)	96.7	97.4	98.1	98.2
Gearbox eff (%)	98.1	98.5	99	99.2
ICE eff (%)	42.8	43.5	44	44.8
ICE type (%)	90.9 (Diesel) 8.5 (CNG) 0.5 (LNG) 0.09 (Ethanol)	96.7(Diesel) 0.9 (CNG) 2.4 (LNG) 0.02 (Ethanol)		

**Table 23** Class 5 truck ICE powertrain specifications from JRC

ICCT depict cycle-averaged engine efficiency (WHTE) for the top-selling manufacturers for conventional fuel type ICE (Diesel / NG) [ICCT, 2021].

ICE displacement dependent efficiency information (class 5: 13L) as well as (class 9: 15L) powertrain is given as well as manufacturer dependent ICE efficiency information.

Average estimation shows 42.1% efficiency for Diesel and 37.5% efficiency for gas engine. and 8.5% CNG for 5-RD subgroup.

Efficiency (%)	ICE 13L	ICE 15L
DAF	43(Diesel)	
IVECO	41(Diesel) 37.5(Gas)	
MAN	43(Diesel)	44 (Diesel)
MERCEDES BENZ	42.5(Diesel)	42 (Diesel)
RENAULT	40(Diesel)	
SCANIA	43(Diesel) 37 (Gas)	40 (Diesel)
VOLVO	42(Diesel)	40 (Diesel)
<b>AVERAGE</b>	42.1 (Diesel) 37.3 (Gas)	41.5 (Diesel)

**Table 24** Class 5 truck ICE status from ICCT

For the drivetrain, JEC Wheel to Tank report V5 proposes most common (not average!) specifications in the fleet of the class 5 truck ICE for gearbox [JEC, 2020]

	Model year 2016
Gear nb. (-)	12
Gear ratio (-)	14.93 11.64 9.02 7.04 5.64 4.4 3.39 2.65 2.05 1.6 1.28 1
Axle ratio (-)	2.64
Axle eff (%)	96
Gearbox eff (%)	96 (indirect gears) 98 (direct gears)
ICE peak BTE (%)	45.8

**Table 25** Class 5 truck gearbox specification from JEC

*HEV / PHEV Powertrain*

For HEV and PHEV powertrain dedicated to Long Haul truck, JEC and IFPEN/ADEME propose both generic ICE B7 HEV and PHEV specifications. [JEC, 2020], [ADEME, 2022]

	<i>Xev ICE B7 2016- JEC</i>	<i>E4T2040 xEV Diesel</i>
Category	Class 5 - 4x2	Class 5 4x2
Range	1816km (2016) / 2042km (2025)	
ICE (displacement(L)/power(kW)/torque (Nm) / nominal speed(rpm))	13L - 325kW	12.8L -400kW 2700Nm @ 1000rpm
Battery (energy (kWh)/ power(kW)/voltage (V))	10kWh (HEV)	Bat_25kWh_250kW_800V (HEV) Bat_130kWh_250kW_800V (PHEV)
Motor (peak power (kW)/torque (Nm))	140kW	EM_250kW_1100Nm
Gearbox	AMT 12	AT 12

**Table 26** Class 5 xHEV specifications from JEC and ADEME/IFPEN

*BEV with battery Powertrain*

For class 5 BEV, several manufacturers’ initiatives can be underlined and compared with generic BEV powertrain proposed by JEC and ADEME/IFPEN studies. [JEC, 2020], [ADEME, 2022]. The figure below shows main specifications of commercial class 5 BEV (blue) and selected value for average vehicle in simulation (red)

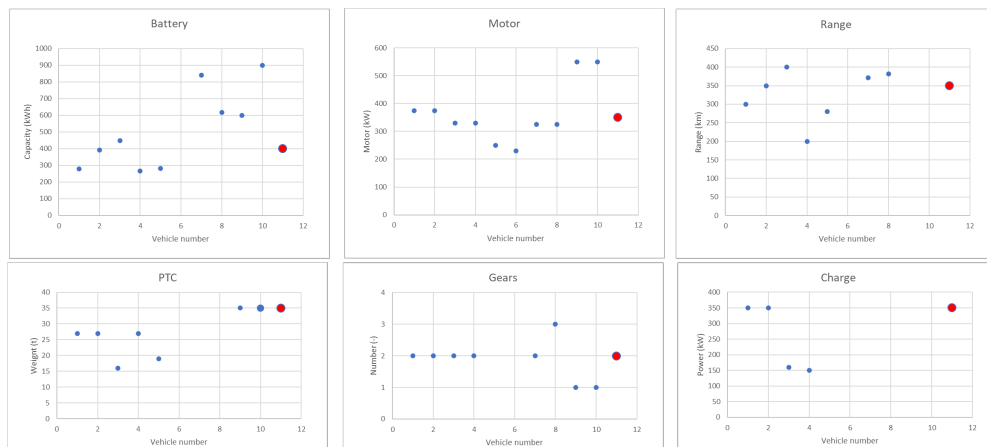

**Figure 25** Class 5 commercial BEV specifications

	Quantron QHM BEV	e-Actros 400 Daimler	FE - VOLVO	LF Electric - DAF	ie truck - Irizar	BEV 2016-JEC	BEV 2025-JEC	E4T 2040
Category	Class 5 4x2 or 6x2	Class 5 6x2	Class 5 Carrier 4x2, 6x2		Class 5 4x2 or 6x2	Class 5 - 4x2	Class 5 - 4x2	Class 5 4x2
Range	300km / 350km	400km	200km	280km		371km	382km	
Battery energy	280kWh / 392kWh	4x112kWh (448kWh)	265 kWh	282kWh		840kWh	616kWh	Bat_600kWh_250kW_800V Bat_900kWh_250kW_800V
Motor power	375kW	330kW (cont)	330kW - 850Nm PTO - 70kW - 530Nm	250kW (cont) - 1200Nm	230kW (cont) - 2360Nm	325kW	325kW	EM_550kW_2000Nm
Gears		2 gears +2 rev.	2 gears			AMT 2 R (8.43; 2.775)	AMT 3 R (14.93; 4.83; 2.02)	Axle ratio 11.5
Charge	350kW DC	160kW DC	22kW / Fast 150kW	150kW DC				
Weight		27t	27t	19t / 11.7t payload				

Table 27 Class 5 BEV specifications from commercial JEC and ADEME/IPFEN

BEV with fuel cell Powertrain

Several prototypes and commercial initiatives for class 5 trucks with FCEV powertrains can be highlighted as well as JEC and IPFEN/ADEME studies propose generic FCEV powertrain for 2025 long haul truck. The figure below shows main specifications of commercial class 5 FCEV (blue) and selected value for average vehicle in simulation (red)

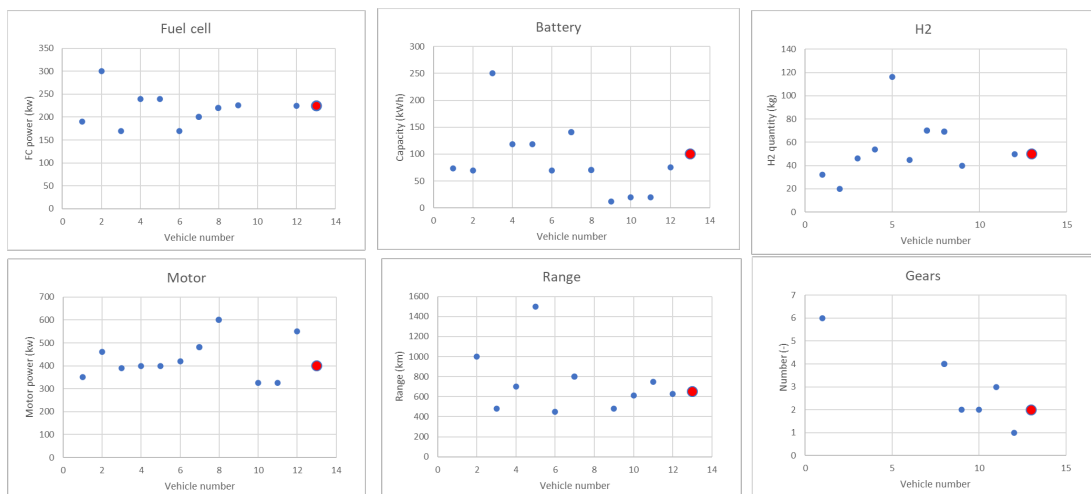

Figure 26 Class 5 commercial FCEV specifications

	Hyundai Xcient H2	Mercedes GenH2	Cathoype	Quantron QHM	Go	Nikola/IVECO tre	Toyota Beta (proto)	FCEV 2016 / 2025 JEC V5
Category	Class 5 - 4x2 - 36t		Class 5 6x2	Class 5 4x2 - 6x2	Class 5 6x2	Class 5 6x2	Class 8	Class 5 4x2
Range		1000km	450 to 480 km	1500km / 700km	450km	800km	482 km	614km (2016) 746km (2025)
Fuel Cell power	2 x 95kW = 190kW	300kW (Volvo)	170 kW	2x120kW = 240kW	170kW	2x100kW	2x113kW = 226kW (Mirai)	
H2 tank capacity	32.09kg @ 350 bar		46kg @ 350bar	116kg /54kg	45kg	70kg@ 700bar	40kg @ 700bar	
Battery energy	Li-ion 661V   73.2kWh	70kWh   400kW	250kw	118kWh	70kwh	2x70kWh	12kWh	20kWh
Motor power	Siemens 350kW   3400Nm	460kW (en 2 MEL)	390kw 2200nm	400kW	420kw	480kW		325kW
Gears	ATM S4500 Allison 6 gears		Bv 6 rear axle 5.8					2 gears (2016) 3 gears (2025)
Weight	10t wo load 19t carrier / 36t tractor	Payload 25t						

**Table 28** Class 5 FCEV specifications from manufacturers and JEC

### Energy consumption

Status on fuel / energy consumption for class 5 truck depending on subgroup and powertrain type can be depicted also from literature review.

	Average 5-RD	Average 5-LH	Best in class 5-RD	Best in class 5-LH	Study
[ICCT, 2021]	33.2L/100km (Diesel)	30.0L/100km (Diesel)			
[JRC, 2022]	33.6L/100km (Diesel)	29.9L/100km (Diesel)	29.2L/100km (Diesel)	27.7L/100km (Diesel)	
[ICCT, 2023]					33.05L/100km (Diesel) 28.8kg/100km (Gas) 138kWh/100km (EV) 238kWh/100km (FCEV)
[JEC, 2020]					29.2 / 26.4 L/100km (B7-2016/2025) 27.1 / 24.7L/100km (CNG - 2016/2025)
[ADEME, 2022]					31.8L/100km (Diesel) 10.2kg/100km (ICE H2) 9.3kg/100km (PHEV H2) 8 / 7 kg/100km (FCEV 55% /65% eff)

**Table 29** Class 5 vehicle consumption from literature review

#### 7.1.1.2. Delivery truck

##### Vehicle specifications

Rigid delivery truck can be considered as class 2 or class 4 in EU 2019/1942

For current study class 2 - 16t rigid truck vehicle is considered as Delivery truck.

JRC defines the average delivery truck coming from CO<sub>2</sub> emissions of the European heavy duty vehicle fleet analysis [JRC, 2022]. This delivery truck is a class 4 - 19t. Two types of class 4 truck with dedicated vehicle specificities are depicted: 4-RD dedicated to “regional delivery” and 4-LH dedicated to “long haul mission”.

Average and best in class vehicle specifications are considered.

	Average 4-RD	Average 4-LH	Best in class 4-RD	Best in class 4-LH
CdxA (m <sup>2</sup> )	5.45	5.16	4.56	4.19
Curb mass (kg)	6328	7675	5408	7149
RRC (kg/t)	Axle 1: 5.7 Axle 2: 6.4	Axle 1: 5.2 Axle 2: 5.8	Axle 1: 4.9 Axle 2: 5.2	Axle 1: 4.0 Axle 2: 4.9
Average payload (kg) EU 2019/1242,2019	3180	7420	3180	7420

**Table 30** Delivery truck vehicle specification from JRC

In JEC Wheel to Tank report V5 a most common (not average) specifications in the fleet of delivery truck for model year 2016 and 2025 is proposed. 2025 specifications are estimated considering 1.1%/year CO<sub>2</sub> reduction and implemented on vehicle and powertrain as well [JEC, 2020].

	Model year 2016	Model year 2025
CdxA (m <sup>2</sup> )	5.6	-0.21
Curb mass + curb mass body (kg)	5800+2100 (ICE Diesel)	-200
Rolling Resistance Coefficient - RRC (kg/t)	Axle 1: 5.5 Axle 2: 6.1	-1%
Payload (kg)	Low: 900 (50%) Rep: 4400 (50%)	

**Table 31** Delivery truck vehicle specification from JEC

In a study dedicated to HDV, ICCT aggregates CO<sub>2</sub> emissions and vehicle main specifications from the top-selling truck brands in the baseline data coming from “CO<sub>2</sub> emissions of the European heavy duty vehicle fleet analysis”. For the delivery truck class 4 ,3 subgroups (4-UD, 4-RD and 4-LH) have different specifications. [ICCT, 2021].

	Average 4-UD	Average 4-RD	Average 4-LH
Curb mass (kg)	DAF: 5600 Scania: 6100	DAF: 5800 IVECO: 5900 MAN: 6000 Mercedes: 6800 Renault: 6100 Scania: 7000 Volvo: 6200	DAF: 6300 IVECO: 7000 MAN: 7000 Mercedes: 7100 Renault: 7000 Scania: 7200 Volvo: 7100
Rolling Resistance Coefficient - RRC (kg/t)	DAF: 6 Scania: 6.1	DAF: 6.0 IVECO: 6.2 MAN: 6.4 Mercedes: 6.0 Renault: 6.1 Scania: 6.15 Volvo: 6.0	DAF: 5.8 IVECO: 6 MAN: 6.1 Mercedes: 5.5 Renault: 5.8 Scania: 5.8 Volvo: 5.9

**Table 32** Delivery truck vehicle specification from ICCT

In IFPEN/ADEME Tranphyn study dedicated to hydrogen HDV evaluation, the main following specifications for average delivery truck (class 2) were considered [ADEME, 2022].

	Delivery truck
CdxA (m <sup>2</sup> )	4.83
Curb mass + curb mass body (kg)	7000 (Ref Diesel)
RRC (kg/t)	7.7
Payload (kg)	4000

**Table 33** Delivery truck vehicle specification from IFPEN/ADEME

### Powertrains specifications

#### Conventional ICE Powertrain

JRC defines the average class 4 truck ICE powertrain. The 4-RD dedicated to “regional delivery” and the 4-LH dedicated to “long haul mission”. [JRC, 2022]. They consider average and best in class powertrain specifications.

Mainly exclusively Diesel CI powertrain (>97%) and some CNG.

	Average 4-RD	Average 4-LH	Best in class 4-RD	Best in class 4-LH
Gear nb. (-)	12	12	12	12
Last gear ratio (-)	0.86	0.98		
Axle ratio (-)	3.97	2.56		
Axle eff (%)	94.8	97.1	96.6	98.1
Gearbox eff (%)	96.7	98.4	98.3	99.1
ICE eff (%)	39.9	43.1	41.6	44.2
ICE nature (%)	97.6 (Diesel) 2.3 (CNG) 0. 1(LNG) 0 (Ethanol)	99.4 (Diesel) 0.04 (CNG) 0. 54(LNG) 0 (Ethanol)		

**Table 34** Delivery truck conventional ICE powertrain specification from JRC

JEC Wheel to Tank report V5 propose most common (not average!) specifications in the fleet of the class 4 delivery truck for drive ICE powertrain for model year 2016 [JEC, 2020].

	Model year 2016
Gear nb. (-)	12
Gear ratio (-)	10.369 8.428 6.487 5.273 4.182 3.40 2.48 2.015 1.551 1.216 1 0.813
Axle ratio (-)	4.11
Axle eff (%)	96
Gearbox eff (%)	96 (indirect gears) 98 (direct gears)
<b>ICE peak BTE (%)</b>	<b>44.3</b>

**Table 35** Delivery truck conventional ICE powertrain gearbox specification from JEC

Regarding ICE performance, ICCT depicts cycle-averaged engine efficiency (WHTE) for the top-selling manufacturers. [ICCT, 2021]. Only fuel type ICE (Diesel / CNG) is considered. Manufacturer efficiency performance depending on displacement is highlighted. An average estimation shows 39% efficiency for Diesel and 37% efficiency for CNG.

Efficiency (%)	ICE 8L	ICE 11L
DAF	38 (Diesel)	43.5(Diesel)
IVECO	39 (Diesel) 37.5(Gas)	40(Diesel)
MAN	40 (Diesel)	41(Diesel)
MERCEDES BENZ	40 (Diesel)	42(Diesel)
RENAULT	38 (Diesel) 37 (Gas)	41(Diesel)
SCANIA	40 (Diesel)	38(Diesel) 37 (Gas)
VOLVO	38 (Diesel) 37 (Gas)	41(Diesel)
<b>AVERAGE</b>	<b>39 (Diesel)</b> <b>37 (Gas)</b>	<b>40.9 (Diesel)</b> <b>37 (Gas)</b>

**Table 36** Delivery truck conventional ICE performance status from ICCT

#### *HEV/PHEV Powertrain*

For HEV/PHEV powertrain, JEC and IFPEN/ADEME studies propose generic ICE B7 HEV, PHEV for 2016 / 2025 class 2 delivery truck. One commercial initiative from SCANIA can be presented also as reference [JEC, 2020], [ADEME, 2022]

	PHEV P 280 - SCANIA	Xev ICE B7 2016- JEC Tank-To-Wheels report v5	xHEV E4T2040
Category	Class 4 - 4x2, 6x2, 6x2*4	Class 4 - 4x2	Class 2 4x2
Range	60km ZEV (PHEV)	1468km	
ICE (displacement(L)/Power(kW)/Torque (Nm) / Nominal speed( rpm))	7L 250-280ch 9L 320-360ch	13L - 325kW	7.1L -225kW 1130Nm @ 1500rpm
Battery (energy (kWh)/ power(kW)/voltage (V))	90kWh (PHEV) 30kWh (HEV)	3kWh (HEV)	Bat_13kWh_120kW_800V (HEV) Bat_60kWh_120kW_800V (PHEV)
Motor (peak power (kW)/torque (Nm))	230 kW (290kW peak) - 2 100 Nm (x2 e-motor)	80kW	EM_120kW_800Nm
Gearbox	6 gears	AMT 12	
Weight	10t without load 19t carrier truck / 36t carrier truck		

**Table 37** Delivery truck xHEV powertrain specifications

**BEV with battery Powertrain**

Several commercial initiatives for Class 2 /Class 4 BEV due to ZFE development can be observed among manufacturers with dispersed battery energy. The figure below shows main specifications of commercial class 2 BEV (blue) and selected value for average vehicle in simulation (red).

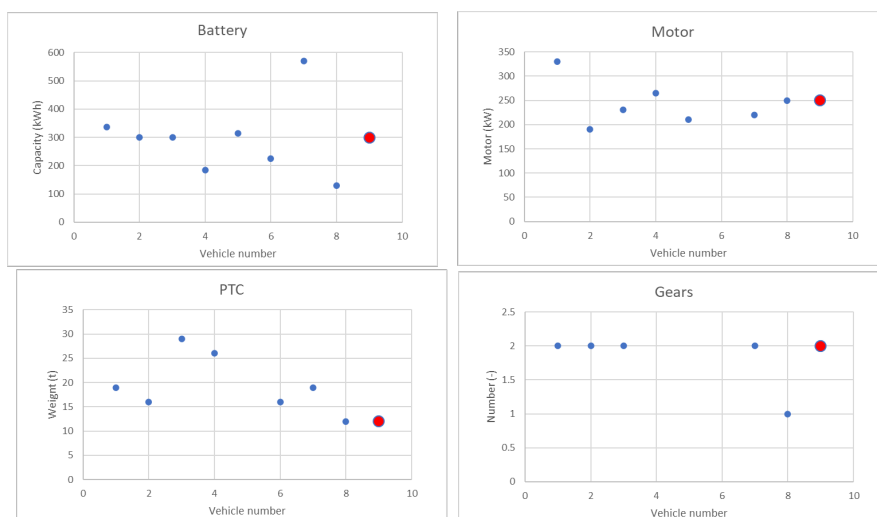

**Figure 27** Class 2 commercial BEV specifications

Moreover, JEC study proposes a generic class 4 and IFPEN/ADEME study a class 2 specification that can help for generic BEV delivery truck specifications [JEC, 2020], [ADEME, 2022].

Ref	eActros 300 - DAIMLER	FL electric - VOLVO	P / L - Scania	eTGM - MAN	CF Electric - DAF	Volta Zero - Volta truck	BEV 2016- JEC Tank-To-Wheels report v5	E4T 2040
Category	Class 4 - 4x2	Class 2 4x2	Class 4 4x2, 6x2 ou 6x2/4	Class 4 - 4x2			Class 4 - 4x2	Class 2 4x2
Range	300km	300km	250km	190km	220km	150 / 200km	350km	
Battery energy	3x112kWh (336kWh)	200 / 395kWh	300kWh	185kWh	315kWh	225kWh	570kWh	Bat_130kWh_250kW_800V
Motor (power (kW) / Torque (Nm))	330kW (cont)	130kW	230kW - 1300Nm (cont) PTO - 60kW	265kW - 3100Nm	210kW - 2000Nm		220kW	EM_250kW_1100Nm
Gearbox	2 gears +2 rev.	2 gears	2 gears				AMT 2 R (8.43; 2.775)	Axle ratio 11.5
Weight	19t	16t	29t	26t carrier		16t (6t payload)		
Charge	160kW DC	22kW + AC	130kW	22 / 44kW				

**Table 38** Delivery truck BEV with battery powertrain specifications

#### BEV with fuel cell Powertrain

Similarly, to long haul truck, several initiatives dedicated to class 4 /class 2 delivery truck FCEV due to recent H2 EU incentive policies can be noted. Moreover, JEC and IFPEN/ADEME studies propose a generic H2 FCEV powertrain for 2016 / 2025 delivery truck [JEC, 2020], [ADEME, 2022].

A specific notice can be done for this vehicle category with 2 main tendencies observed for powertrains depending on range target: #1 “FCEV base vehicle”: vehicle with a large fuel cell and a small battery and #2 “FCEV range extender vehicle”: vehicle with a small fuel cell coupled with a medium battery. The figure below shows main specifications of commercial class 2 FCEV (blue) and selected value for average vehicle #1 and #2 in simulation (red)

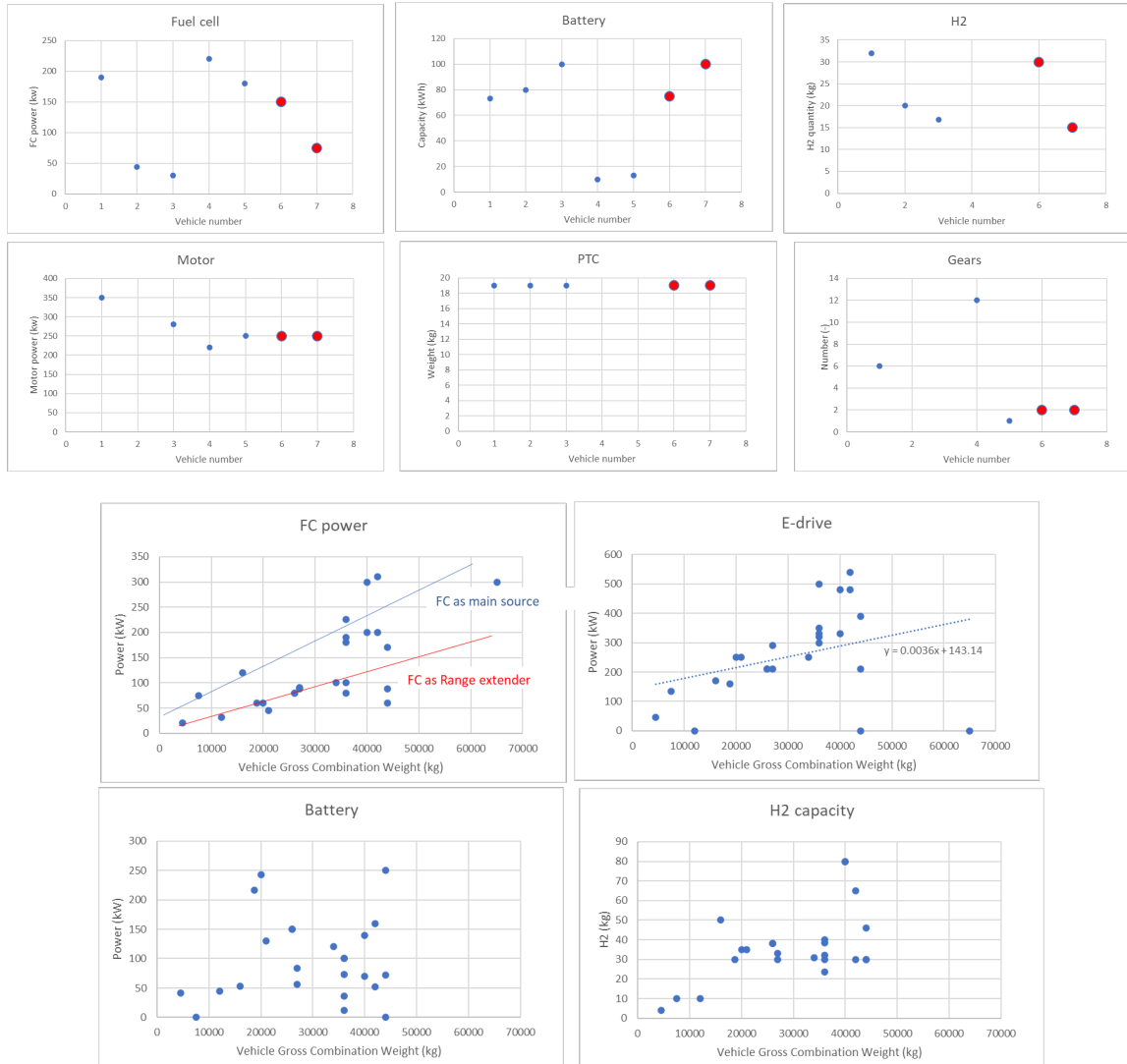

Figure 28 Class 2 commercial FCEV specifications

Ref	Hyundai Xcient H2	Electr (UK)	E-neo Retrofit	FCEV 2016-JEC	Tranplyn 2022 - IFPEN
Category	Class 4 - 4x2	Class 4 - 4x2 -carrier	Class 4 - 4x2 -carrier	Class 4 - 4x2	Delivery truck
Range	400km (18t)	500km	250 à 300km 50 à 70km (battery only)	608km	
Fuel Cell	2 x 95kW = 190kW	44kw	30kw	220kW	FC_180kW
H2 tank	32.09kg @ 350 bar	20kg @ 350 bar	16.8 kg@ 350 bar	700L @ 700bar	
Battery	Li-ion 661V   73.2kWh	225 kWh -> 80kWh	100kwh	10kWh	Bat_13kWh_250kW_800V
Motor	Siemens 350kW   3400Nm		280kw	220kW	EM_250kW_1100Nm
Transmission	ATM S4500 Allison 6 gears + rev			2 gears	Axle ratio 11.5
Weight	10t without load 19t carrier truck / 36t tractor	19t	19t	19t	19t

**Table 39** Delivery truck BEV with fuel cell powertrain specification

### **Energy consumption**

Status on fuel consumption for delivery truck for every powertrain can be depicted from literature for current as well as prospective vehicles.

Study	Current	Prospective
[JRC,2022]	Average current 24L/100km 4-RD (Diesel) 29.1L/100km 4-LH (Diesel) Best in class 21.2L/100km 4-RD(Diesel) 27L/100km 4-LH (Diesel)	
[ICCT,2023]	26L/100km (Diesel) 22.7kg/100km (Gas) 110kWh/100km (EV) 190kWh/100km (FCEV)	
[JEC,2020]	<b>2016</b> 22.2 / 22L/100km (Diesel B7/ B100) 20.4L/100km (HEV / B7) 20.2kg/100km (CNG) 18.4kg/100km (HEV / CNG) 1.43MJ/tkm with charge loss (BEV) 4.47kg/100km (FCEV)	<b>2025</b> 20.3 / 23.9L/100km (Diesel B7/ B100) 18.8L/100km (HEV / B7) 18.4kg/100km (CNG) 16.7kg/100km (HEV / CNG) 1.23MJ/tkm with charge loss (BEV) 3.88kg/100km (FCEV)

**Table 40** Delivery truck consumption status from literature review

### 7.1.1.3. City bus

#### *Vehicle specifications*

Various categories of city buses encompass a range of sizes and configurations, from minibuses to lengthy 18-meter articulated buses. However, the focus of the CONCAWE study is on the 12-meter non-articulated city bus, which is one of the most prevalent types encountered in urban environments. Characteristics of this specific bus can often be found in literature.

It's worth noting that the IFPEN/ADEME Tranplhyn study delineates the specifications of a 30-ton / 18-meter articulated bus, while the VECTO tool defines a generic city bus, which is likely a smaller-scale city bus, possibly resembling a mini city bus with a medium curb mass [ADEME, 2022]



	VECTO 2022	Tranplhyn 2022
Type	generic	18m articulated city bus 30t
CdxA (m2)	4.83	5.5
Curb mass (kg)	6570	16445
RRC (kg/t)	6.5	7
Payload (kg) Distribution (%)	3020	Max: 11200 (160passengers) Mass distribution: 20% - 0 / 50% - 5600 / 30% - 11200 Average: 6160

**Table 41** City bus vehicle specifications from literature

### ***Powertrain specifications***

#### ***Conventional ICE Powertrain***

VECTO tool and IFPEN/ADEME study define generic conventional ICE powertrain for a generic city bus as follows:

	VECTO 2022	Tranphlyn 2022
Gear nb. (-)	AT 6 speeds with torque converter	AT 9 speeds
Gear ratio (-)	1: 3.4 2: 1.9 3: 1.42 4: 1 5: 0.7 6: 0.62	1: 9.48 2: 6.58 3: 4.68 4: 3.48 5: 2.62 6: 1.89 7: 1.35 8: 1 9: 0.6
Axle ratio (-)	6.2	4.5
Axle eff (%)	98	98
Gearbox eff (%)	98	98
ICE eff (%)		40

	VECTO 2022	Tranphlyn 2022
ICE Diesel (displacement (L) / Power (kW) / Inertia (kg/m <sup>2</sup> ) Max torque (Nm) and nominal speed(rpm))	6.8L - 175kW 3.56kg/m <sup>2</sup> 1200Nm @ 1200rpm / 175kW @ 2200rpm	7.1L - 220kW / 2.7kg/m <sup>2</sup> 1130Nm @ 1200rpm /
ICE CNG	-	-
ICE H2		9.3L - 220kW / 3.2kg/m <sup>2</sup> 1200Nm @ 1200rpm

**Table 42** City bus conventional ICE powertrain specifications from literature

#### HEV / PHEV powertrain

Commercial initiatives for City bus: 12m / 18m (with xHEV powertrain) can be noticed. Generally, with ~20% hybridization rate for HEV and ~50% for PHEV.

	Citaro C2G - MERCEDES BENZ	Citywide LF - SCANIA	Bus urbanway - IVECO	I4 hybrid - IRIZAR	Bus Urbanway Hybrid - IVECO	Citaro G hybrid - MERCEDES BENZ
Type	ICE	ICE	ICE	HEV	HEV	PHEV
Category	18m	12m / 18m	18m	12m	18m	18m - 132 passengers
ICE (displacement (L) /power (kW) / Torque (Nm))	220kW - 1200Nm	Diesel 7L -1200Nm / 206kW 9L - 1600Nm / 235kW CNG 9L - 1350Nm / 206kW 9L - 1600Nm / 250kW	Diesel 8.7L - 1600Nm / 265kW CNG 8L - 1300NM / 240kW	Diesel 6,7l - 1200 Nm/ 220kW	Diesel 6.7L - 1200Nm / 210kW	4.8L 160kW
Battery energy				small	??	26kWh
Motor(nom/max power kW)				44 kW / 65 kW peak	35kW	160kW
Gearbox		6 gears	6 gears	6 gears	6 gears	

**Table 43** City bus xHEV powertrain specifications from literature

#### BEV with battery Powertrain

A lot of demonstrations and commercial products for BEV City bus with centralized e-motor or e-wheel and with medium -300kWh to very large battery capacity ~700kWh depending on range objectives. Some recent examples are described below (in bleu):

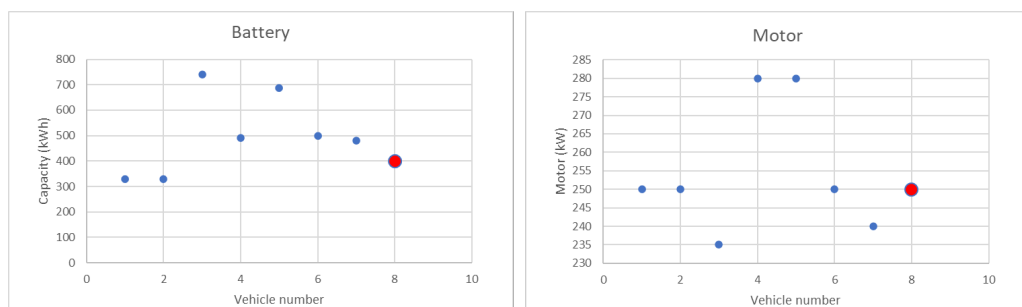

**Figure 29** City bus commercial BEV specifications

	eCitaro G - MERCEDES BENZ	Citywide LF - electric SCANIA	le18 bus - IRIZAR	A12 /18 BATTERIJ - VAN HOOL	Ebusco 3.0 - EBUSCO	Lion's City 12E - MAN
Category	18m	12m / 18m	18m	12m /18m	12 / 18m	12m
Range	350km				575km (12m) 700km (18m)	350km
Battery energy	330kWh	264kWh or 330kWh	Up to 740kWh	490kWh (12m) 686kWh (18m)	350kWh (12m) 500kWh (18m)	480kWh
Motor power/torque	2x125kW - 2x485Nm (wheel motor)	250kW - 2100Nm	235kW - 2300Nm	2x140kW (wheel motor)	2x125kW (wheel motor)	240kW - 2100Nm
Gearbox		2 gears				
Charge		150kW DC	500kW			
Weight	28500kg (158passengers)			(51 seats)	18.6t (95 passengers-12m) 26.6t (150 passengers-18m)	104 passengers

**Table 44** City bus BEV with battery powertrain specifications from literature

*BEV with fuel cell Powertrain*

Similarly, to truck, recent commercial and prototype initiatives for FCEV City bus can be noticed with small FC and medium to large battery (FCEV range extender type powertrain) to medium FC and small battery depending on expected trade off. The figure below shows main specifications of commercial city bus FCEV (blue) and selected value for average vehicle in simulation (red)

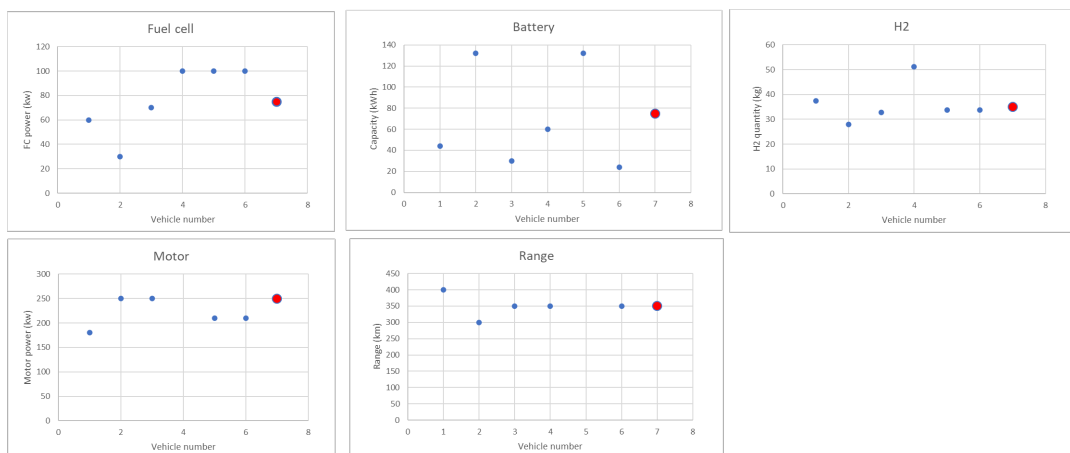

**Figure 30** City bus commercial FCEV specifications

	Caetano H2 - TOYOTA	Businova - SAFRA	eCitaro FCEV - Mercedes	Urbino 12 - SOLARIS	Urbino 18 - SOLARIS	A18 FC - VAN HOOL	A330FC - VAN HOOL
Category	10.5/ 12m	9/ 10,5 / 12m	12m / 18m	12m	18m articulated	18m articulated	12m
Range	400km	300km	400 / 350km	350km	350km		350km
Fuel Cell power	60kW	30kW	60W (Toyota)	70kW	100kW	100kW (Ballard)	100kW
H2 tank capacity	37.5kg @ 350bar	28kg @ 350bar	25 / 35kg @ 350bar	32.8 à 350bar	51.2kg @350bar		33.8L @ 350bar
Battery energy	44kWh	132kWh	294kWh/ 392kWh	30kWh	60kWh	132kWh	24kWh
Motor power/torque	180kW	250kW	125 -425Nm / 250 -850Nm	2x125kW		210kW	160kW / 210kW peak
Transmission							
Weight				29t (140 passengers)	29t (140 passengers)	(51 seats)	20t

**Table 45** City bus BEV with fuel cell powertrain specifications from literature

### **Energy consumption**

Status on fuel consumption for city bus can be depicted from literature comparing powertrain and energy carrier. These consumptions are average ones with sometimes no information regarding driving profile.

Study	Average
[ICCT, 2023] (12m/ 18m bus)	55.8L/100km (ICE Diesel) 47.5kg/100km (ICE Gas) 170kWh/100km (BEV) 305kWh/100km (FCEV)
[CATP, 2022] (12m bus)	SORT 1 cycle 42,9 L/100km (Diesel/HVO) 44,8 L/100km (B100) 45,3 kg/100km (CNG) 36,4L/100km (Diesel MHEV) 30,8L/100km (Diesel FHEV) 125 kWh/100 km (BEV) 7,5 to 9,5 kg / 100km (FCEV)
[ADEME, 2022] TRANPLHYN (18m) E4T2040 (2022)	63.6L/100km (ICE Diesel) 10kg/100km (ICE H2) 11.8kg/100km (FCEV @ 55% peak eff.) 10.2kg/100km (FCEV @ 65% peak eff.)
[ARGONNE, 2014]	-9kg/100km (FCEV London fleet 12m bus)

**Table 46** City bus energy consumption status from literature

#### 7.1.1.4. Interurban bus

##### *Vehicle specifications*

Generic interurban bus dedicated to mobility between cities and coach are considered here. VECTO and IFPEN/ADEME Tranplhyn study define a generic interurban. [ADEME,2022]

	VECTO 2022	Tranplhyn 2022
CdxA (m2)	4.115	4.5
Curb mass (kg)	14800	11445
Rolling Resistance Coefficient - RRC (kg/t)	6.5	7
Payload (kg) Distribution (%)	5170	Max : 11 200 (160 passengers) Mass distribution : 20% - 0 50% -30 passengers 30% - 60 passengers Average: 33 passengers (70kg/passenger)

**Table 47** Interurban bus vehicle specifications from literature

## Powertrain specifications

### Conventional ICE Powertrain

VECTO tool and IFPEN/ADEME study define generic conventional ICE powertrain for a generic interurban bus as follows:

	VECTO 2022	Tranplhyn 2022
ICE Diesel (displacement (L) / power(kW) / inertia (kg/m <sup>2</sup> ) / Max torque (Nm) /Nominal speed (rpm)	7.7L-250kW- 3.79kg/m <sup>2</sup> 1641Nm @ 1000rpm / 250kW @ 1750rpm	7.1L - 220kW / 2.7kg/m <sup>2</sup> 1130Nm @ 1200rpm /
ICE GNV	-	-
ICE H2		9.3L - 220kW / 3.2kg/m <sup>2</sup> 1200Nm @ 1200rpm
Gear nb. (-)	MT 6 speeds	AT 9 speeds
Gear ratio (-)	1: 3.36 2: 1.91 3: 1.42 4: 1 5: 0.72 6: 0.62	1: 9.48 2: 6.58 3: 4.68 4: 3.48 5: 2.62 6: 1.89 7: 1.35 8: 1 9: 0.6
Axle ratio (-)	4.9	4.5
Axle eff (%)	98	97
Gearbox eff (%)	98	97

**Table 48** Interurban bus conventional powertrain specification from literature

*HEV / PHEV powertrain*

Most of commercial interurban buses are equipped with conventional Diesel and CNG powertrains. Few commercial initiatives are available for hybrid Coach (only HEV with small 48V battery).

	I4 hybrid - IRIZAR	Inturo Hybrid - MERCEDES	Crossway Hybrid - IVECO
Type	HEV	HEV	HEV
Category	12m	12m	12m
ICE (displacement (L) / power(kW) / torque (Nm))	Diesel 6,7l - 1200 Nm / 220kW	Diesel 7.7L -1400Nm / 260kW 10.6L - 1700Nm / 265kW	Diesel 8.7L - 1600Nm / 265kW CNG 8.7L - 1300Nm / 265kW
Battery	small	Small 48V	Small 48V
Motor power / torque	44 kW / 65 kW peak	14kW - 220Nm	35kW
Gearbox	6 gears	6 gears	

**Table 49** Interurban bus xHEV powertrain specification from literature

**BEV with battery Powertrain**

Few commercial initiatives for BEV Coach (always with very big battery for large autonomy target). The figure below shows main specifications of commercial interurban bus BEV (blue) and selected value for average vehicle in simulation (red)

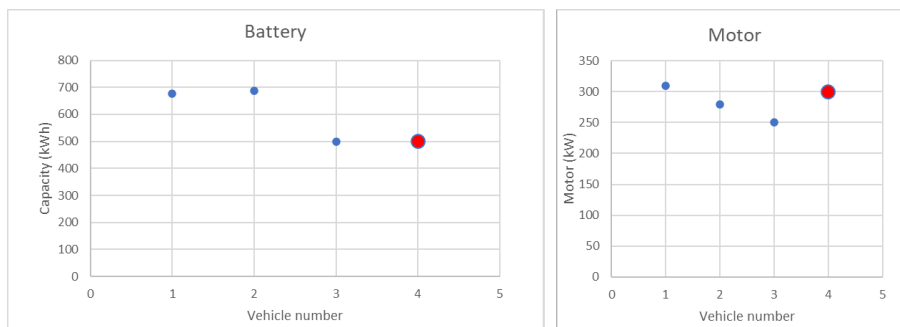

**Figure 31** Interurban bus commercial BEV specifications

	CX45E - VAN HOOL	A13 BATTERIJ - VAN HOOL	Ebusco 3.0 - Ebusco
Category	13m	13m	12 / 18m
Range	420		600km
Battery energy	676kWh	686kWh (13m)	250 to 500kWh
Motor power/torque	310kW - 420Nm	2x140kW (wheel motor)	250kW
Transmission			
Charge	125kW		
Weight	56 passengers	(51 seats)	

**Table 50** Interurban bus BEV powertrain specification from literature

*BEV with fuel cell Powertrain*

In the same way as trucks, commercial solutions developed for interurban bus propose alternatives to large autonomy solution without large battery powertrains. Dispersed specification for FCEV coach can be observed (battery / FC size compromise). Example of vehicle are proposed in the table below:

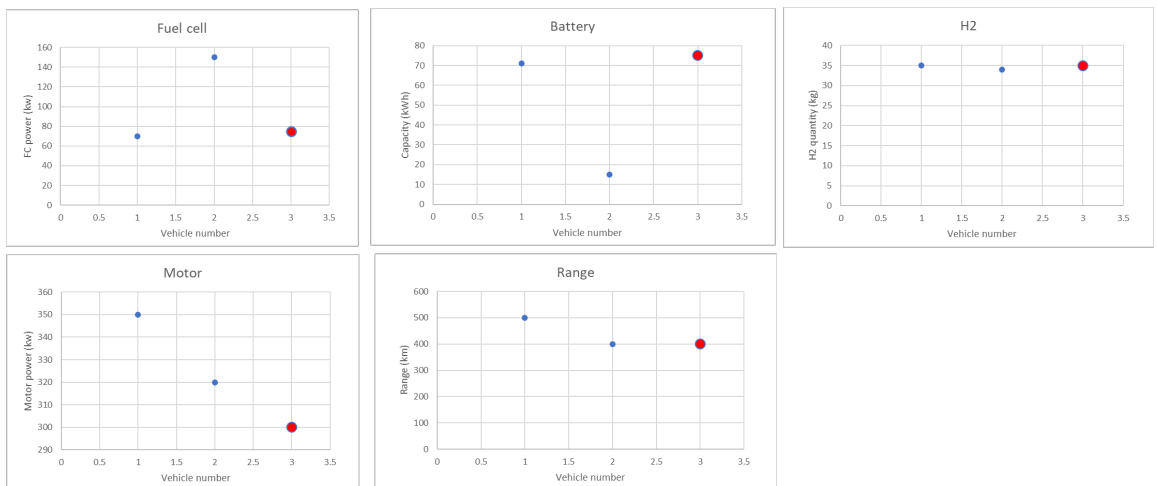

**Figure 32** Interurban bus commercial FCEV specifications

	Intouro FC - MERCEDES	Crossway FC- IVECO
Category	12m	12m / 19t
Range	500km	400km
Fuel Cell power	70kW (Plastic Omnium)	150kW (Symbio)
H2 tank capacity	35kg @ 350bar	34kg @ 700bar (Forvia)
Battery energy	71kWh NMC	15kWh
Motor power	350kW	320kW

**Table 51** Interurban bus FCEV powertrain specification from literature *Energy consumption*

Status on fuel consumption for interurban bus for some powertrain can be depicted from literature.

Study	Average
[ADEME, 2022]	34.6L/100km (ICE Diesel) 10.5kg/100km (ICE H2) 6.8kg/100km+/-0.5 (FCEV H2)

**Table 52** Interurban bus energy consumption status from literature

#### 7.1.1.5. Refuse truck

##### *Vehicle specifications*

Different refuse truck categories exist (from mini cab to multi axles depending on the load). CONCAWE study wants to focus on 26t / 3 axles refuse truck (the most common buses encountered in European city). Some vehicle characteristics can be found in literature as VECTO tool that defines generic refuse truck.

	VECTO 2022
CdxA (m2)	5.2
Curb mass (kg)	11500
RRC (kg/t)	6.5 axle 1-2 6.5 Axle3
Payload (kg) Distribution (%)	7100

**Table 53** Refuse truck vehicle generic specifications.

### Powertrains specifications

#### Conventional ICE Powertrain

JRC study analyses Refuse truck from Environmental services company of Milan (AMSA) in 2020. [JRC,2020] Diesel and CNG powertrain were considered with the following ICE specifications. The ICE powertrain configuration is like VECTO specifications.

	JRC AMSA study
ICE Diesel	7.7L - 220kW - 1200Nm @ 1200rpm / 220kW @ 2200rpm
ICE GNV	7.7L - 222kW - 1200Nm @ 1200rpm / 220kW @ 2200rpm

**Table 54** Refuse truck ICE powertrain specifications for JRC study

#### HEV / PHEV powertrain

Some commercial initiatives for hybrid refuse trucks (only PHEV for zero emission / low noise collection phase). Here are some examples with available data of conventional and PHEV powertrains coming from literature.

	Stralis AD260S33YPS - IVECO	TGA 26.310 - MAN	P320 LB 6x2 REFUSE TRUCK - SCANIA	P 360 - Scania	Premium Distribution Hybrys Tech - Renault truck
Type	CNG	Diesel	Diesel	PHEV	PHEV
Category	26t 6x2	26t - 6x2		26t 6x2	26t 6x2
ICE power	CNG - 242kW	Diesel - 230kW	Diesel 9.3L - 235kW	B7 / B100 - 265kW	Diesel 7.1 - 235kW
Battery				90kWh 60km ZEV	??
Motor					70kW
Transmission		8 gears	8 gears	8 gears	

**Table 55** Commercial ICE and PHEV refuse truck

#### BEV with battery Powertrain

Few commercial initiatives exist for BEV Refuse. High payload involves medium to large battery capacity. The figure below shows main specifications of commercial BEV refuse truck (blue) and selected value for average vehicle in simulation (red):

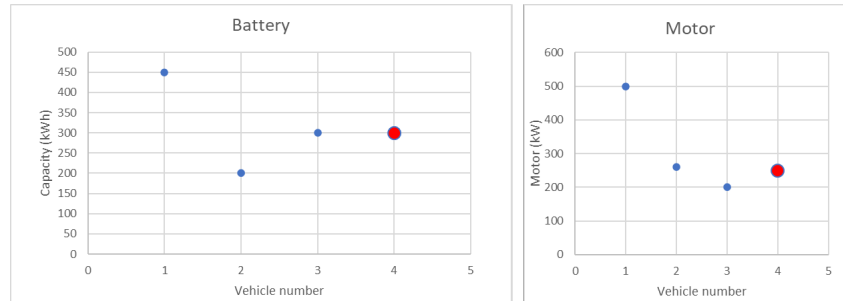

**Figure 33** Refuse truck commercial BEV specifications

	Futuricum collect 26E - Design Werk AG	D Wide Z.E - Renault truck	ERCV - Dennis Eagle
Category	Carrier 6x2	Refuse 4x2	Refuse 6x2
Powertrain type	BEV	BEV	BEV
Range	250km (collect mode)	120km	
Battery energy	450kWh	200kWh	300kWh
Motor power	500kW	260kW - 850Nm	200kW
Transmission		2 gears	
Weight	26t (10t load)	26t	26t

**Table 56** Commercial BEV refuse truck

*BEV with fuel cell Powertrain*

Similarly, to other electrified HDV, refuse truck with fuel cell tend to develop. Powertrain specification of 2 commercial initiatives from Hyundai and Hyzon are presented as well as FCEV Refuse truck demonstrators coming from current EU program. It can be observed dispersed specifications with different battery capacity / FC power trade-off.

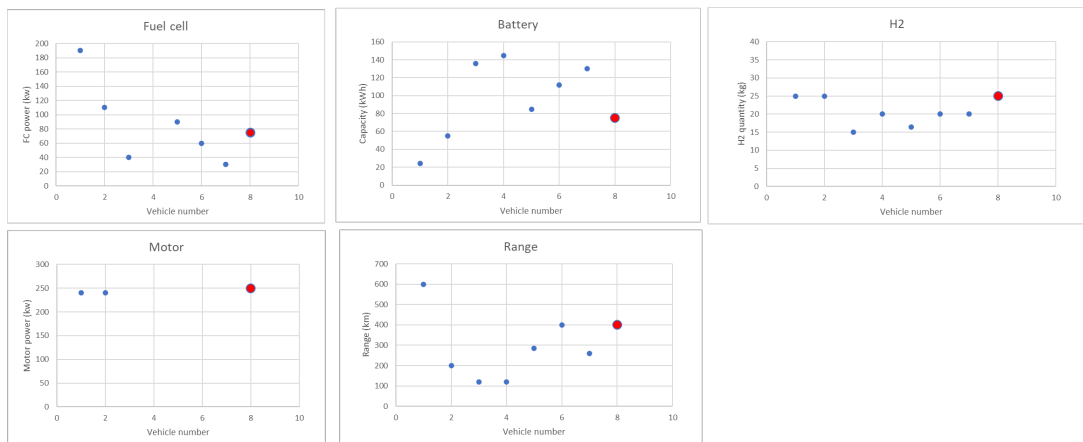

**Figure 34** Refuse truck commercial FCEV specifications

	Garbage Truck - HYUNDAI	Refuse truck - Hyzon	CF 340 FC-DAF	ECONIC - MERCEDE S	FAUN / DAIMLER	SEMAT / MERCED ES	DAF
Category	Refuse 6x2	Refuse 6x2	Refuse 6x2	Refuse 6x2	Refuse 6x2	Refuse 6x2	Refuse 6x2
Range	599km	200km (1500 coll. Phase)	120km	120km	285km	400km	260km
Fuel Cell power	95kWx2 (NEXO)	110kW	40kW	??	30kWx3 (Hydrogenics)	30kWx2	30kW (Ballard)
H2 tank capacity	25kg @ 700bar	25kg @ 350bar	15kg @ 350bar	20kg @ 350bar	16.4kg @ 700bar	20kg @ 700bar	20kg @ 350bar
Battery energy	24.4kWh	55kWh	136kWh	145kWh	85kWh	112kWh	130kWh
Motor power	240kW	240kW	??	??	??	??	??
Gearbox			6 gears AT	??	??	??	??
Weight	26t (4.5t payload)	29t (11t payload)					

**Table 57** Commercial FCEV refuse truck

**Energy consumption**

Status on fuel consumption for refuse truck for FCEV powertrain can be depicted from literature.

Study	Average
Hyzon refuse truck	12.5kg/100km
[ABERDEEN, 2021] HECTOR EU program	12.5kg/100km (DAF) 16.6kg/100km (Mercedes) 5.8kg/100km (DAIMLER)

**Table 58** Refuse truck energy consumption status from literature

### 7.1.2. Appendix 2: Vehicle / powertrain review from literature

In this part of the report, details on selected specifications of nominal vehicles and powertrains defined for the five generic vehicle categories are presented. This selection is coming from literature review detailed in appendix 1

#### 7.1.2.1. Long haul truck

##### *Vehicle*

	Nominal vehicle
CdxA (m2)	5.6
Curb mass + trailer mass (kg)	15000 (ref Diesel) 15020 (CNG) 15889 (H2) 15241(HEV) 16046(PHEV) 16221(BEV) 15449(FCEV)
Rolling resistance coefficient - RRC (kg/t)	Axle 1: 5.0 Axle 2: 5.5
Auxiliaries load (W)	5000
Payload (kg) Distribution (%)	Low: 2 600 Rep: 19 000 Max: up to 29 000 (2% 5-UDL; 3% 5-RDL; 24% 5-LHL) (4% 5-UDR; 7% 5RDR; 60% 5-LHR)

**Table 59** Long haul truck nominal vehicle specifications for simulation

**Powertrains**

	ICE	HEV	PHEV	BEV	FCEV
ICE (energy carrier / displacement (L) / power(kW) / torque (Nm) / efficiency (%))	Diesel 12.8L - 400kW 2700Nm @ 1000rpm - 46% CNG 12.9L - 340kW 2000Nm @ 1100rpm - 36.5% H2 15.2L - 410kW 1950Nm @1100rpm - 44.1%	Diesel 12.8L - 400kW 2700Nm @ 1000rpm - 46%	Diesel 12.8L - 400kW 2700Nm @ 1000rpm - 46%	-	-
Fuel cell (power (kW) / efficiency (%) /H2 capacity (kg))	-	-	-	-	225kW - 65% - 50kg
Motor power (kW)	-	150kW	250kW	350kW	350kW
Battery energy (kWh)	-	20kWh	130kWh	400kWh	100kWh
Gearbox ratio (-)	12	12	12	2	2

**Table 60** Long haul truck powertrains specification for simulation

### Gearbox

	ICE / xHEV	EV
Gear nb. (-)	12	2
Gear ratio (-)	14.93 11.64 9.02 7.04 5.64 4.4 3.39 2.65 2.05 1.6 1.28 1	11.1 2.775
Axle ratio (-)	2.64	2.6
Axle eff (%)	96	96
Gearbox eff (%)	98	98
Motor peak eff (%)		96
DC/DC constant eff (%)		95

**Table 61** Long haul truck gearbox specification for simulation

### 7.1.2.2. Delivery truck

#### Vehicle

	Nominal vehicle
CdxA (m2)	5.5
Curb mass + curb mass body (kg)	7900 (ref ICE Diesel) 7964 (CNG) 8300 (H2) 8172(HEV) 8746(PHEV) 8998 (BEV) 8248(FCEV)
Auxiliaries load (W)	3540
Rolling resistance coefficient - RRC (kg/t)	Axle 1: 5.5 Axle 2: 6.1
Payload (kg)	Low: 900 Rep: 4400 Max: up to 8100

**Table 62** Delivery truck vehicle nominal specifications for simulation

### Powertrains

ICE	ICE	HEV	PHEV	BEV	FCEV
ICE (energy carrier / displacement (L) / power(kW) / torque (Nm) / efficiency (%))	Diesel 7.1L -225kW 1130Nm @ 1500rpm 42.4% CNG 7.1L - 225kW 1150Nm @ 1300rpm 36% H2 9.3L - 220kW 1100Nm @1200rpm 44.1%	Diesel 7.1L - 225kW 1130Nm @ 1500rpm 42.4%	Diesel 7.1L - 225kW 1130Nm @ 1500rpm 42.4%	-	-
Fuel cell (power (kW) / efficiency (%) / H2 capacity (kg))	-	-	-	-	225kW - 65% - 30kg
Motor power (kW)	-	100kW	250kW	250kW	250kW
Battery energy (kWh)	-	30kWh	100kWh	300kWh	20kWh
Gearbox ratio (-)	12	12	12	2	2

**Table 63** Delivery truck powertrain specification for simulation

**Gearbox**

	ICE /xHEV	EV
Gear nb. (-)	12	2
Gear ratio (-)	10.369 8.428 6.487 5.273 4.182 3.40 2.48 2.015 1.551 1.216 1 0.813	11.1 2.775
Axle ratio (-)	4.11	2.6
Axle eff (%)	96	96
Gearbox eff (%)	98	98
Motor peak eff (%) DC/DC constant eff (%)		96 95

**Table 64** Delivery truck gearbox specification for simulation

7.1.2.3. City bus  
Vehicle

	Nominal vehicle
CdxA (m2)	4.85
Curb mass (kg)	11500 (Ref Diesel) 11548(CNG) 11963 (H2) 11592 (HEV) 12281 (PHEV) 13265 (BEV) 11807 (FCEV)
Auxiliaries Load (W)	5000
Rolling resistance coefficient - RRC (kg/t)	6.5
Payload (kg) Distribution (%)	Low: 1000 (15 peoples) Rep: 3000 (42 peoples) Max: up to 6300 (90 peoples) With an average mass of 70kg/pers

**Table 65** City bus vehicle nominal specifications for simulation

**Powertrains**

	ICE	HEV	PHEV	BEV	FCEV
ICE (energy carrier / displacement (L) / power(kW) / torque (Nm) / efficiency (%))	Diesel 7.1L - 225kW 1130Nm @ 1500rpm 42.4% CNG 7.1L - 225kW 1150Nm @ 1300rpm 36% H2 9.3L - 220kW 1100Nm @1200rpm 44.1%	Diesel 7.1L - 225kW 1130Nm @ 1500rpm 42.4%	Diesel 7.1L - 225kW 1130Nm @ 1500rpm 42.4%	-	-
Fuel cell (power (kW) / efficiency (%) / H2 capacity (kg))	-	-	-	-	75kW - 65% - 35kg
Motor power (kW)	-	35kW	160kW	250kW	250kW
Battery energy (kWh)	-	10kWh	35kWh	400kWh	75kWh
Gearbox ratio (-)	6	6	6	2	2

**Table 66** City bus powertrains specification for simulation

### Gearbox

	ICE /xHEV	EV
Gear nb. (-)	6	2
Gear ratio (-)	1: 3.4 2: 1.9 3: 1.42 4: 1 5: 0.7 6: 0.62	11.1 2.77
Axle ratio (-)	6.2	2.6
Axle eff (%)	96	96
Gearbox eff (%)	98	98
Motor peak eff (%)		96
DC/DC constant eff (%)		95

**Table 67** City bus gearbox specification for simulation

#### 7.1.2.4. Interurban bus

##### Vehicle

	Nominal vehicle
CdxA (m2)	4.115
Curb mass (kg)	14800 (Diesel) 14781(CNG) 15180 (H2) 14892(HEV) 15148(PHEV) 17168(BEV) 15293(FCEV)
Auxiliaries Load (W)	5000
RRC (kg/t)	6.5
Payload (kg) Distribution (%)	Low: 2100 (30 peoples - no luggage) Rep: 5100 (60 peoples with 15kg luggage) With an average mass of 70kg/pers

**Table 68** Interurban vehicle nominal specifications for simulation

**Powertrains**

	ICE	HEV	PHEV	BEV	FCEV
ICE (energy carrier / displacement (L) / power(kW) / torque (Nm) / efficiency (%))	Diesel 7.7L -250kW 1400Nm @ 1200rpm 46% CNG 7.1L - 225kW 1150Nm @ 1300rpm 36% H2 9.3L - 220kW 1100Nm @1200rpm 44.1%	Diesel 7.7L - 250kW 1400Nm @ 1200rpm 46%	Diesel 7.7L - 250kW 1400Nm @ 1200rpm 46%	-	-
Fuel cell (power (kW) / efficiency (%) / H2 capacity (kg))	-	-	-	-	225kW - 65% - 35kg
Motor power (kW)	-	120kW	250kW	300kW	300kW
Battery energy (kWh)	-	25kWh	100kWh	500kWh	75kWh
Gearbox ratio (-)	6	6	6	2	2

**Table 69** Interurban bus powertrains specification for simulation

**Gearbox**

	ICE / XHEV	EV
Gear nb. (-)	6	2
Gear ratio (-)	1: 3.4 2: 1.9 3: 1.42 4: 1 5: 0.7 6: 0.62	11.1 2.77
Axle ratio (-)	6.2	2.6
Axle eff (%)	96	96
Gearbox eff (%)	98	98
Motor eff (%) DC/DC eff (%)		96 95

**Table 70** Interurban gearbox specifications for simulation

### 7.1.2.5. Refuse truck

#### *Vehicle*

	Nominal vehicle
CdxA (m2)	5.2
Curb mass (kg)	11500 (Diesel) 11564(CNG) 11796(H2) 11592(HEV) 12150(PHEV) 12598(BEV) 11640(FCEV)
Auxiliaries Load (W)	3500
Rolling Resistance Coefficient - RRC (kg/t)	6.5
Payload (kg) Distribution (%)	Rep: 7 100 evolutive load during cycle Max: 11 000 evolutive load during cycle

**Table 71** Refuse truck vehicle nominal specifications for simulation

### Powertrains

	ICE	HEV	PHEV	BEV	FCEV
ICE (energy carrier / displacement (L) / power(kW) / torque (Nm) / efficiency (%))	Diesel 7.7L -250kW 1400Nm @ 1200rpm 46% CNG 7.1L - 225kW 1150Nm @ 1300rpm 36% H2 9.3L - 220kW 1100Nm @1200rpm 44.1%	Diesel 7.7L - 250kW 1400Nm @ 1200rpm 46%	Diesel 7.7L - 250kW 1400Nm @ 1200rpm 46%	-	-
Fuel cell (power (kW) / efficiency (%) / H2 capacity (kg))	-	-	-	-	75kW - 65% - 25kg
Motor power (kW)	-	35kW	160kW	300kW	300kW
Battery energy (kWh)	-	10kWh	35kWh	300kWh	75kWh
Gearbox ratio (-)	6	6	6	2	2

**Table 72** Refuse truck powertrains specification for simulation

### Gearbox

	ICE /xHEV	EV
Gear nb. (-)	6	2
Gear ratio (-)	1: 3.4 2: 1.9 3: 1.42 4: 1 5: 0.7 6: 0.62	11.1 2.77
Axle ratio (-)	6.2	2.6
Axle eff (%)	96	96
Gearbox eff (%)	98	98
Motor peak eff (%)		96
DC/DC constant eff (%)		95

**Table 73** Refuse truck gearbox specifications for simulation

**Concawe**  
Av. des Nerviens 85  
1040, Brussels | Belgium

Tel: +32 2 566 91 60  
e-mail: [info@concawe.eu](mailto:info@concawe.eu)  
<http://www.concawe.eu>

